

PARTS CATALOGUE

CZD300-AK (B74C) AUSTRALIA, NEW ZEALAND



1UB74-700E1



CZD300-AK
PARTS CATALOGUE
©2018 by Yamaha Motor Co., Ltd.
1st edition, October 2018
All rights reserved.
Any reprinting or unauthorized use
without the written permission of
Yamaha Motor Co., Ltd.
is expressly prohibited.
Printed in Japan.

FOREWORD

This Parts Catalogue is related to the parts for the model(s) on the cover page. When you are ordering replacement parts, please refer to this Parts Catalogue and quote both part numbers and part names correctly.

1. Modifications or additions which have been made after the issue of the Parts Catalogue will be announced in the Parts News.
It is advisable that you make the necessary corrections to the Parts Catalogue according to the Parts News.

2. Abbreviations

The following abbreviations are used in this Parts Catalogue.

“UR” Use specified parts number.

“UN” Use as many as needed.

“AP” Alternate Parts

“LM” Locally Made (Parts need to be ordered locally)

“F#” Frame No. (Applicable machine No.)

“O/S” Over Size

3. The number of components for assembly

- Parts, which are to be supplied in an assembly, are listed with a dot (.) in front of the part name as shown below.
- The numeral appearing to the right of each component part indicates the quantity of parts for each assembly unit.

PART NO.	DESCRIPTION	Q'TY	REMARKS
2F5-83310-60	FRONT FLASHER LIGHT ASSY	2	
115-83311-60	.BULB (6V-18W)	1	

4. Applicable colours of graphics are represented in the “REMARKS” as shown below.

PART NO.	DESCRIPTION	Q'TY	REMARKS
2N4-24110-00-X5	FUEL TANK COMP.	2	MXR
3J1-24240-10	.GRAPHIC, FUEL TANK	1	FOR MXR

5. Note that the illustrations for reference in finding parts numbers are not to be used for assembling. When assembling, please use the applicable service manual.

6. The asterisk (*) before a reference number indicates modified items after the first edition.

FOREWORD

7. Applicable Serial No.

Engine Serial No.

Frame Serial No.

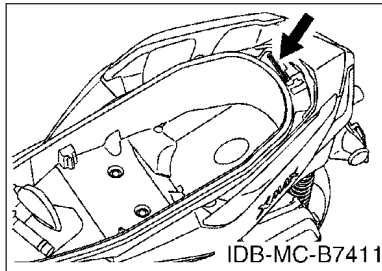
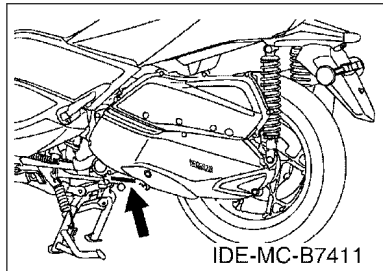

8. Applicable Colour Code (The (*) mark shows Model colour.)

Abbreviation	Colour Name	Colour Code
MBL2(*)	MAT BLACK 2	0582
MS1(*)	MAT SILVER 1	1160
SMX	BLACK METALLIC X	0903
YB	YAMAHA BLACK	0033

CONTENTS

ENGINE

CYLINDER.....	1
CRANKSHAFT & PISTON.....	2
VALVE.....	4
CAMSHAFT & CHAIN.....	6
WATER PUMP.....	7
RADIATOR & HOSE.....	8
OIL PUMP.....	10
INTAKE.....	11
EXHAUST.....	13
CRANKCASE.....	14
CRANKCASE COVER 1.....	16
STARTER.....	17
CLUTCH.....	18
TRANSMISSION.....	20

CHASSIS

FRAME.....	21
FENDER.....	22
SIDE COVER.....	24
REAR ARM & SUSPENSION.....	26
STEERING.....	27
FRONT FORK.....	28
FUEL TANK.....	30
SEAT.....	32
FRONT WHEEL.....	34
FRONT BRAKE CALIPER.....	35
REAR WHEEL.....	36
REAR BRAKE CALIPER.....	37
STEERING HANDLE & CABLE.....	38
FRONT MASTER CYLINDER.....	39
STAND & FOOTREST.....	41
STAND & FOOTREST 2.....	43
LEG SHIELD.....	45
WINDSHIELD.....	48
GENERATOR.....	51
STARTING MOTOR.....	52
FLASHER LIGHT.....	53
METER.....	54
HEADLIGHT.....	55

TAILLIGHT.....	56
HANDLE SWITCH & LEVER.....	57
ELECTRICAL 1.....	58
ELECTRICAL 2.....	60
ELECTRICAL 3.....	61

INDEX

NUMERICAL INDEX.....	62
----------------------	----

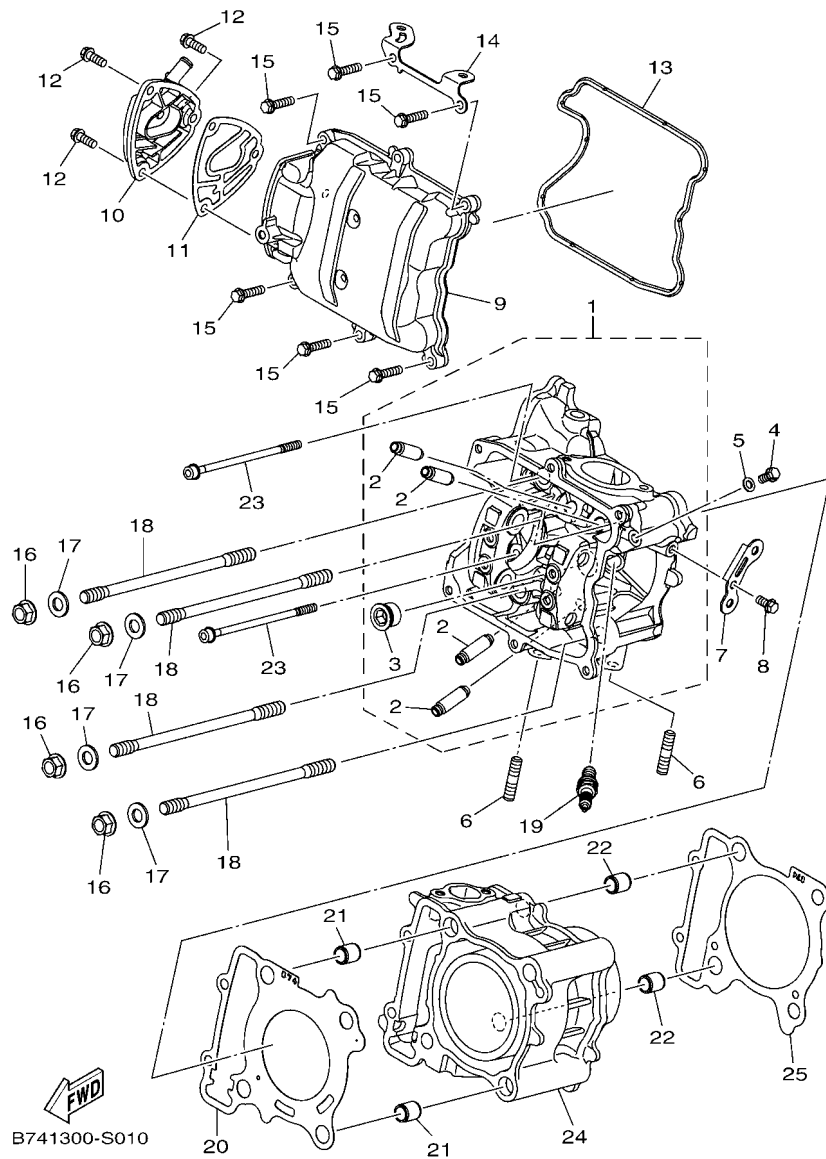
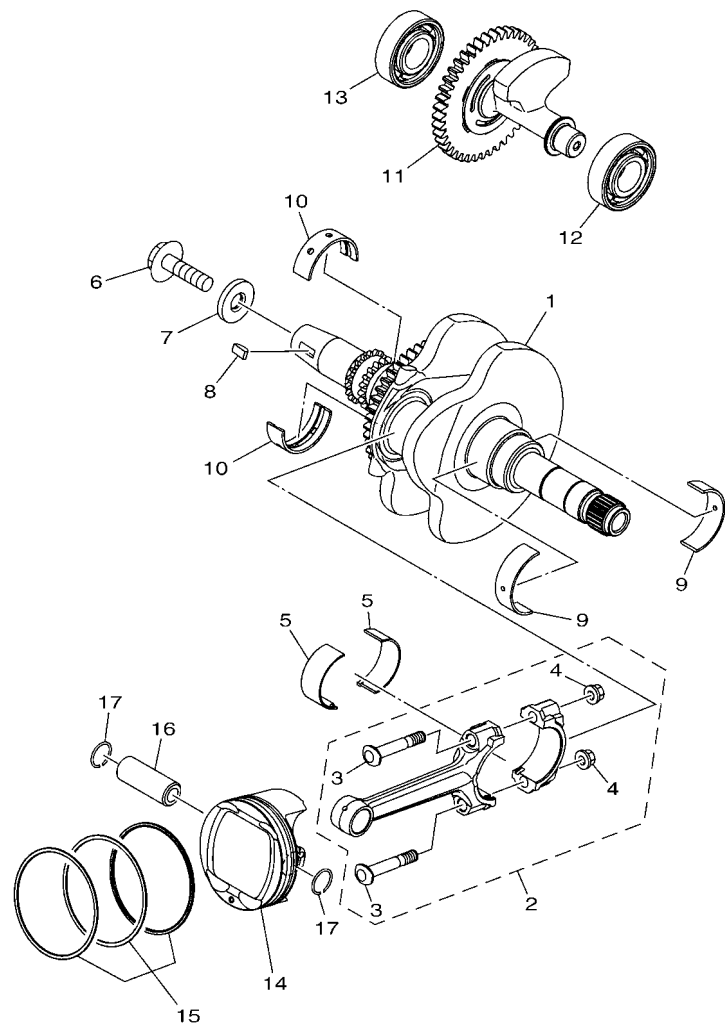

FIG. 1 CYLINDER

REF. NO.	PART NO.	DESCRIPTION	B74C	REMARKS
1	B74-E1102-00	CYLINDER HEAD ASSY	1	
2	B74-E1133-10	.GUIDE, VALVE 1	4	
3	90340-18002	.PLUG, STRAIGHT SCREW	1	
4	95022-06012	BOLT, FLANGE	1	
5	90430-06014	GASKET	1	
6	95612-08620	BOLT, STUD	2	
7	B74-E1998-00	BRACKET 1	1	
8	95022-06012	BOLT, FLANGE	1	
9	B74-E1191-00	COVER, CYLINDER HEAD 1	1	
10	B74-E1185-00	COVER, CYLINDER HEAD SIDE 3	1	
11	B74-E1169-00	GASKET, BREATHER COVER	1	
12	95022-06016	BOLT, FLANGE	3	
13	B74-E1193-00	GASKET, HEAD COVER 1	1	
14	B74-E1999-00	BRACKET 2	1	
15	95022-06025	BOLT, FLANGE	6	
16	90179-10818	NUT	4	
17	90201-10849	WASHER, PLATE	4	
18	B74-11391-00	BOLT, STUD 1	4	
19	94700-00436	PLUG, SPARK (NGK LMAR8A-9)	1	
20	B74-E1181-00	GASKET, CYLINDER HEAD 1	1	
21	99530-14016	PIN, DOWEL	2	
22	99530-14016	PIN, DOWEL	2	
23	90110-06868	BOLT, HEXAGON SOCKET HEAD	2	
24	B74-E1311-00	CYLINDER 1	1	
25	B74-E1351-00	GASKET, CYLINDER	1	

FIG. 2 CRANKSHAFT & PISTON



B741300-S020

REF. NO.	PART NO.	DESCRIPTION	B74C			REMARKS
1	B74-E1400-00	CRANKSHAFT ASSY	1			
2	B74-11650-00	CONNECTING ROD ASSY	1			
3	2C0-11654-00	.BOLT, CONNECTING ROD	2			
4	90179-07001	.NUT	2			
5	B74-11656-00	PLANE BEARING, CONNECTING ROD	2			UR BLUE
	B74-11656-10	PLANE BEARING, CONNECTING ROD	2			UR BLACK
	B74-11656-20	PLANE BEARING, CONNECTING ROD	2			UR BROWN
	B74-11656-30	PLANE BEARING, CONNECTING ROD	2			UR GREEN
6	90105-10883	BOLT, FLANGE	1			
7	90201-10848	WASHER, PLATE	1			
8	90280-05013	KEY, WOODRUFF	1			
9	B74-11416-A0	PLANE BEARING, CRANKSHAFT 1	2			UR WHITE
	B74-11416-00	PLANE BEARING, CRANKSHAFT 1	2			UR BLUE
	B74-11416-10	PLANE BEARING, CRANKSHAFT 1	2			UR BLACK
	B74-11416-20	PLANE BEARING, CRANKSHAFT 1	2			UR BROWN
	B74-11416-30	PLANE BEARING, CRANKSHAFT 1	2			UR GREEN
	B74-11416-40	PLANE BEARING, CRANKSHAFT 1	2			UR YELLOW
	B74-11416-50	PLANE BEARING, CRANKSHAFT 1	2			UR PINK
10	B74-11417-A0	PLANE BEARING, CRANKSHAFT 2	2			UR WHITE
	B74-11417-00	PLANE BEARING, CRANKSHAFT 2	2			UR BLUE
	B74-11417-10	PLANE BEARING, CRANKSHAFT 2	2			UR BLACK
	B74-11417-20	PLANE BEARING, CRANKSHAFT 2	2			UR BROWN
	B74-11417-30	PLANE BEARING, CRANKSHAFT 2	2			UR GREEN
	B74-11417-40	PLANE BEARING, CRANKSHAFT 2	2			UR YELLOW
	B74-11417-50	PLANE BEARING, CRANKSHAFT 2	2			UR PINK
11	B74-E1500-00	BALANCER ASSY	1			
12	93306-303YT	BEARING	1			

FIG. 2 CRANKSHAFT & PISTON

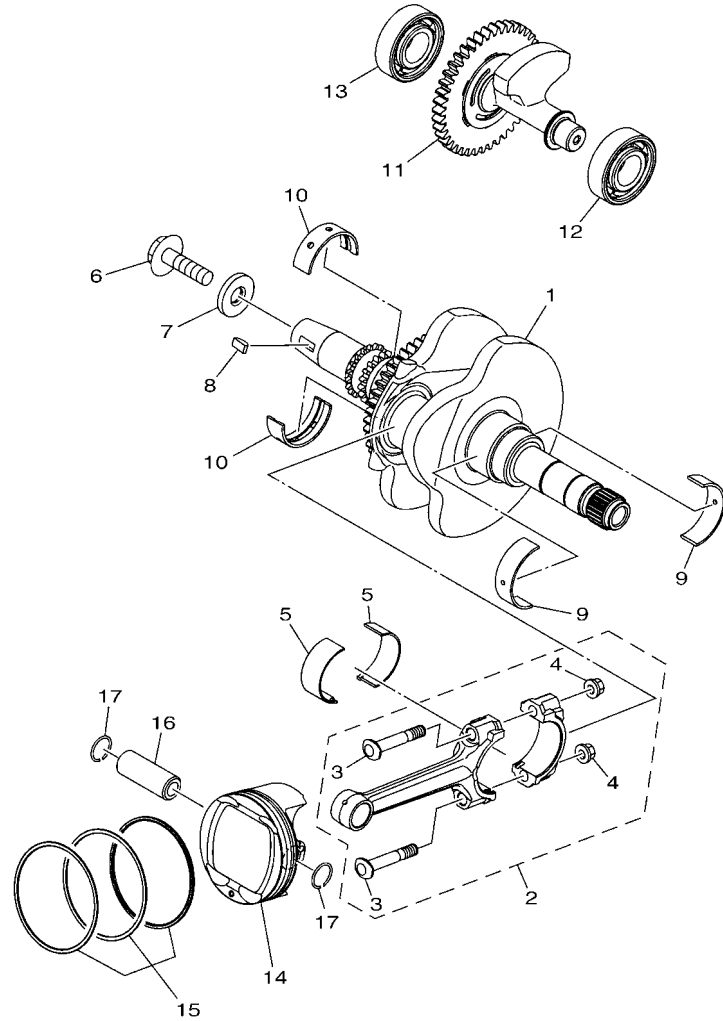

B741300-S020

REF. NO.	PART NO.	DESCRIPTION	B74C			REMARKS
13	93306-204XV	BEARING	1			
14	B74-E1631-01	PISTON (STD)	1			
15	B74-E1603-00	PISTON RING SET (STD)	1			
16	B74-E1633-00	PIN, PISTON	1			
17	93450-17129	CIRCLIP	2			
<hr/>						
<hr/>						
<hr/>						
<hr/>						
<hr/>						
<hr/>						
<hr/>						
<hr/>						
<hr/>						

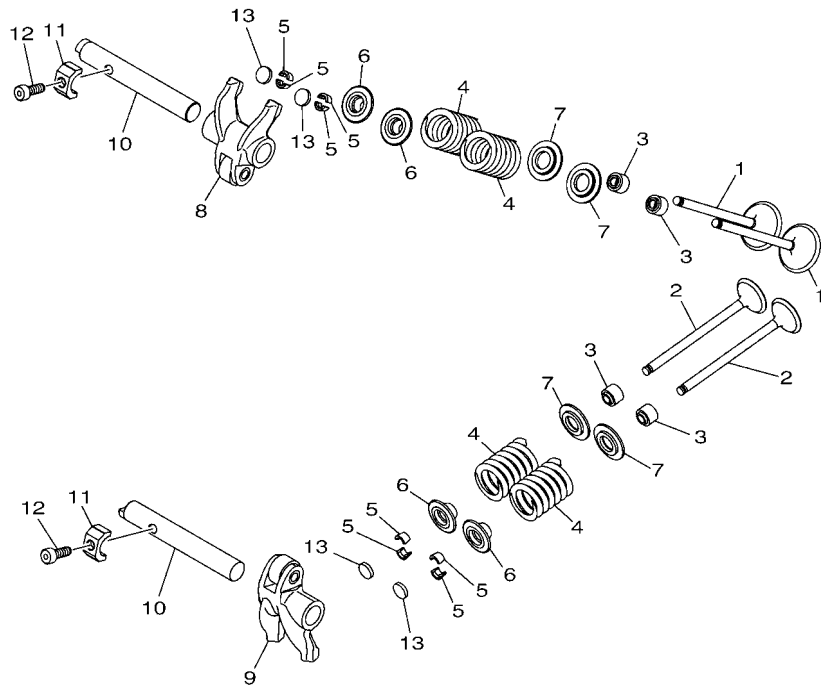

B741300-S030

FIG. 3 VALVE

REF. NO.	PART NO.	DESCRIPTION	B74C				REMARKS
1	B74-E2111-00	VALVE, INTAKE	2				
2	B74-E2121-00	VALVE, EXHAUST	2				
3	54P-E2119-00	SEAL, VALVE STEM	4				
4	B74-E2113-00	SPRING, VALVE INNER	4				
5	5TL-E2118-00	LOCK, VALVE SPRING RETAINER	8				
6	B74-E2117-00	RETAINER, VALVE SPRING	4				
7	2PH-E2126-00	SEAT, VALVE SPRING 2	4				
8	B74-E2151-00	ARM, VALVE ROCKER	1				
9	B74-E2161-00	ARM, VALVE ROCKER 2	1				
10	B74-E2146-00	SHAFT, ROCKER	2				
11	B74-E2662-00	COLLAR 1	2				
12	91312-05014	BOLT, HEXAGON SOCKET HEAD	2				
13	B74-12168-00	PAD, ADJUSTING (1.50)	4				UR
	B74-12168-20	PAD, ADJUSTING (1.55)	4				UR
	B74-12168-40	PAD, ADJUSTING (1.60)	4				UR
	B74-12168-60	PAD, ADJUSTING (1.65)	4				UR
	B74-12168-80	PAD, ADJUSTING (1.70)	4				UR
	B74-12168-A0	PAD, ADJUSTING (1.75)	4				UR
	B74-12168-F0	PAD, ADJUSTING (1.80)	4				UR
	B74-12168-H0	PAD, ADJUSTING (1.85)	4				UR
	B74-12168-K0	PAD, ADJUSTING (1.90)	4				UR
	B74-12168-M0	PAD, ADJUSTING (1.95)	4				UR
	B74-12168-R0	PAD, ADJUSTING (2.00)	4				UR
	B74-12168-U0	PAD, ADJUSTING (2.05)	4				UR
	B74-12168-W0	PAD, ADJUSTING (2.10)	4				UR
	B74-12168-Y0	PAD, ADJUSTING (2.15)	4				UR
	B74-12169-10	PAD, ADJUSTING (2.20)	4				UR

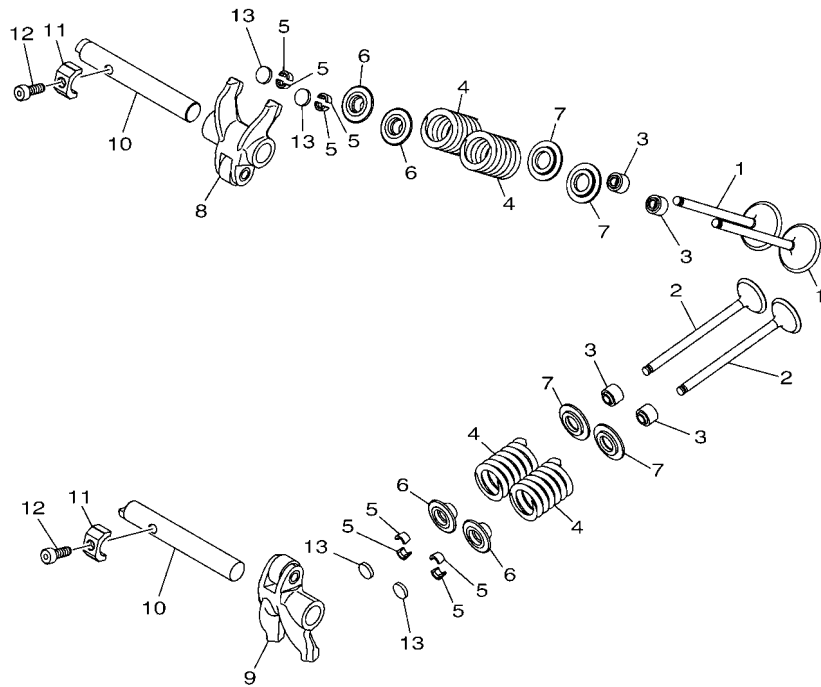

B741300-S030

FIG. 3 VALVE

REF. NO.	PART NO.	DESCRIPTION	B74C			REMARKS
13	B74-12169-30	PAD, ADJUSTING (2.25)	4			UR
	B74-12169-50	PAD, ADJUSTING (2.30)	4			UR
	B74-12169-70	PAD, ADJUSTING (2.35)	4			UR
	B74-12169-90	PAD, ADJUSTING (2.40)	4			UR
	B74-12169-E0	PAD, ADJUSTING (2.45)	4			UR
	B74-12169-G0	PAD, ADJUSTING (2.50)	4			UR
	B74-12169-J0	PAD, ADJUSTING (2.55)	4			UR
	B74-12169-L0	PAD, ADJUSTING (2.60)	4			UR
	B74-12169-N0	PAD, ADJUSTING (2.65)	4			UR
	B74-12169-T0	PAD, ADJUSTING (2.70)	4			UR
	B74-12169-V0	PAD, ADJUSTING (2.75)	4			UR
	B74-12169-X0	PAD, ADJUSTING (2.80)	4			UR
	B74-1216A-00	PAD, ADJUSTING (2.85)	4			UR
	B74-1216A-20	PAD, ADJUSTING (2.90)	4			UR
	B74-1216A-40	PAD, ADJUSTING (2.95)	4			UR
	B74-1216A-60	PAD, ADJUSTING (3.00)	4			UR
	B74-1216A-80	PAD, ADJUSTING (3.05)	4			UR
	B74-1216A-A0	PAD, ADJUSTING (3.10)	4			UR
	B74-1216A-F0	PAD, ADJUSTING (3.15)	4			UR
	B74-1216A-H0	PAD, ADJUSTING (3.20)	4			UR
	B74-1216A-K0	PAD, ADJUSTING (3.25)	4			UR
	B74-1216A-M0	PAD, ADJUSTING (3.30)	4			UR
	B74-1216A-R0	PAD, ADJUSTING (3.35)	4			UR
	B74-1216A-U0	PAD, ADJUSTING (3.40)	4			UR
	B74-1216A-W0	PAD, ADJUSTING (3.45)	4			UR
	B74-1216A-Y0	PAD, ADJUSTING (3.50)	4			UR

FIG. 4 CAMSHAFT & CHAIN

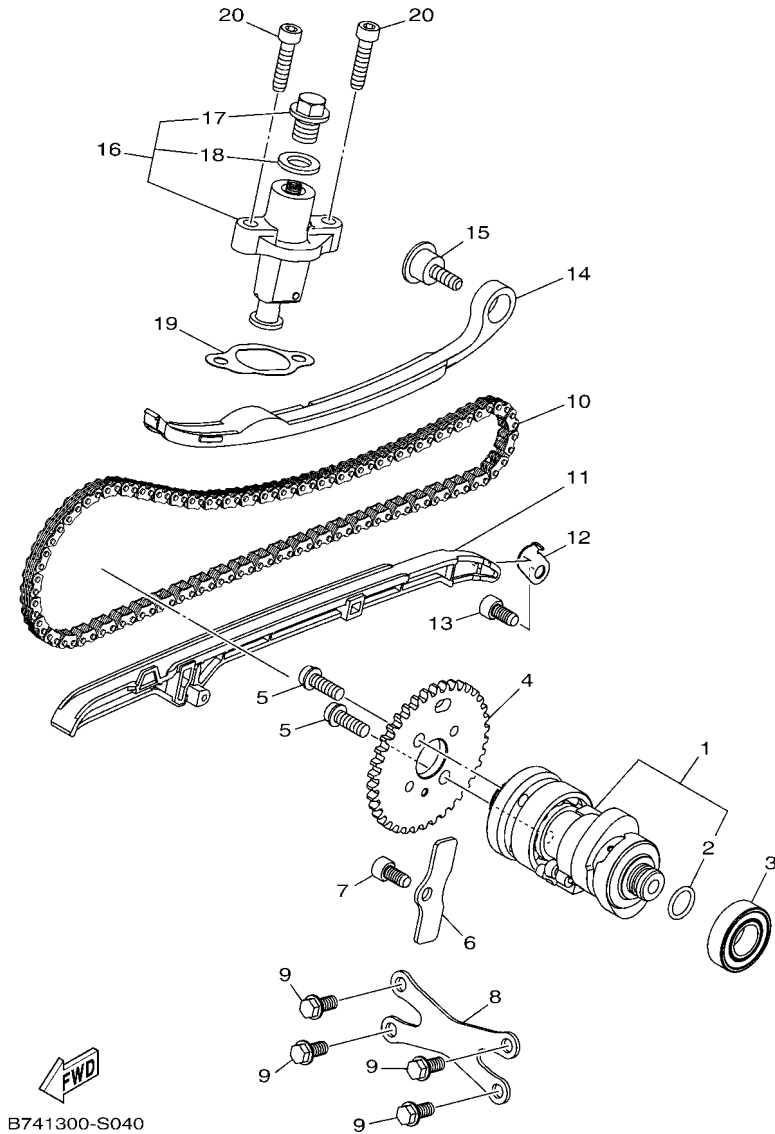

B741300-S040

REF. NO.	PART NO.	DESCRIPTION	B74C				REMARKS
1	B74-E2170-00	CAMSHAFT ASSY 1	1				
2	93210-12801	.O-RING	1				
3	93306-002XH	BEARING	1				
4	B74-E2176-00	SPROCKET, CAM CHAIN	1				
5	90110-06405	BOLT, HEXAGON SOCKET HEAD	2				
6	B74-E112F-00	PLATE 2	1				
7	90110-06187	BOLT, HEXAGON SOCKET HEAD	1				
8	B74-E111F-00	PLATE	1				
9	95022-06012	BOLT, FLANGE	4				
10	94568-H8110	CHAIN	1				
11	B74-E2231-00	GUIDE, STOPPER 1	1				
12	B74-E2233-00	PLATE, GUIDE STOPPER 1	1				
13	90110-06182	BOLT, HEXAGON SOCKET HEAD	1				
14	B74-E2241-00	GUIDE, STOPPER 2	1				
15	1DB-E2228-00	BOLT	1				
16	31G-12210-01	TENSIONER ASSY, CAM CHAIN	1				
17	31G-12222-00	.PLUG	1				
18	31G-12214-00	.GASKET	1				
19	B74-E2213-00	GASKET, TENSIONER CASE	1				
20	91312-06025	BOLT, HEXAGON SOCKET HEAD	2				

FIG. 5 WATER PUMP

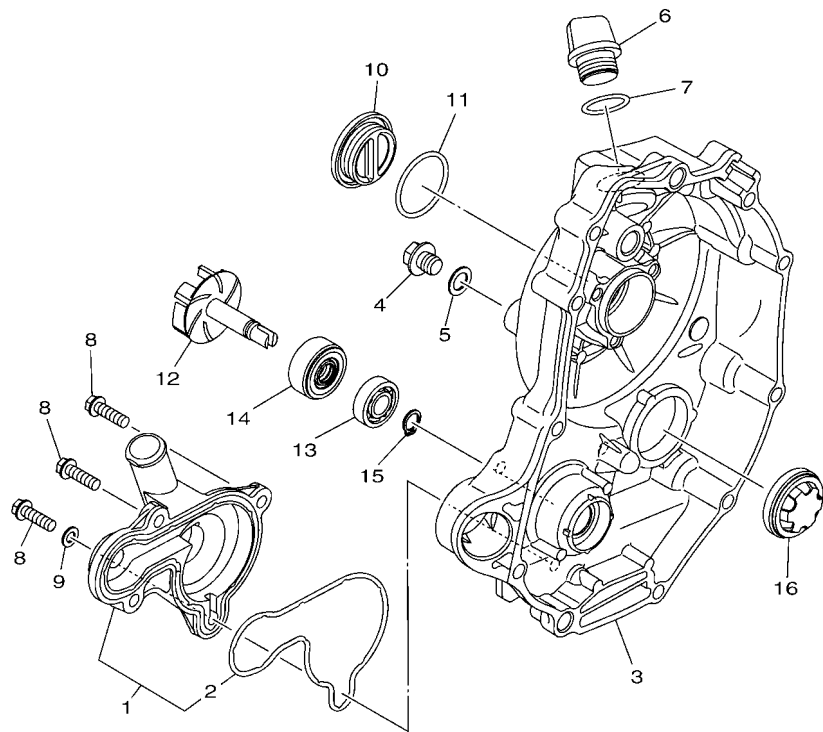

REF. NO.	PART NO.	DESCRIPTION	B74C				REMARKS
1	B74-E2422-00	COVER, HOUSING	1				
2	B74-E2439-00	.O-RING	1				
3	B74-E5417-00	COVER, CAP	1				
4	B74-E2157-00	BOLT	1				
5	90430-10148	GASKET	1				
6	5BP-E5363-10	PLUG, OIL	1				
7	93210-198J0	O-RING	1				
8	95027-06020	BOLT, FLANGE	3				
9	90430-06014	GASKET	1				
10	90340-32805	PLUG, STRAIGHT SCREW	1				
11	93210-32816	O-RING	1				
12	B74-E2450-00	IMPELLER SHAFT ASSY	1				
13	93306-000Y3	BEARING	1				
14	93103-10801	OIL SEAL	1				
15	99009-10400	CIRCLIP	1				
16	5PW-15361-00	GAUGE, LEVEL	1				

 B741300-S050

FIG. 6 RADIATOR & HOSE

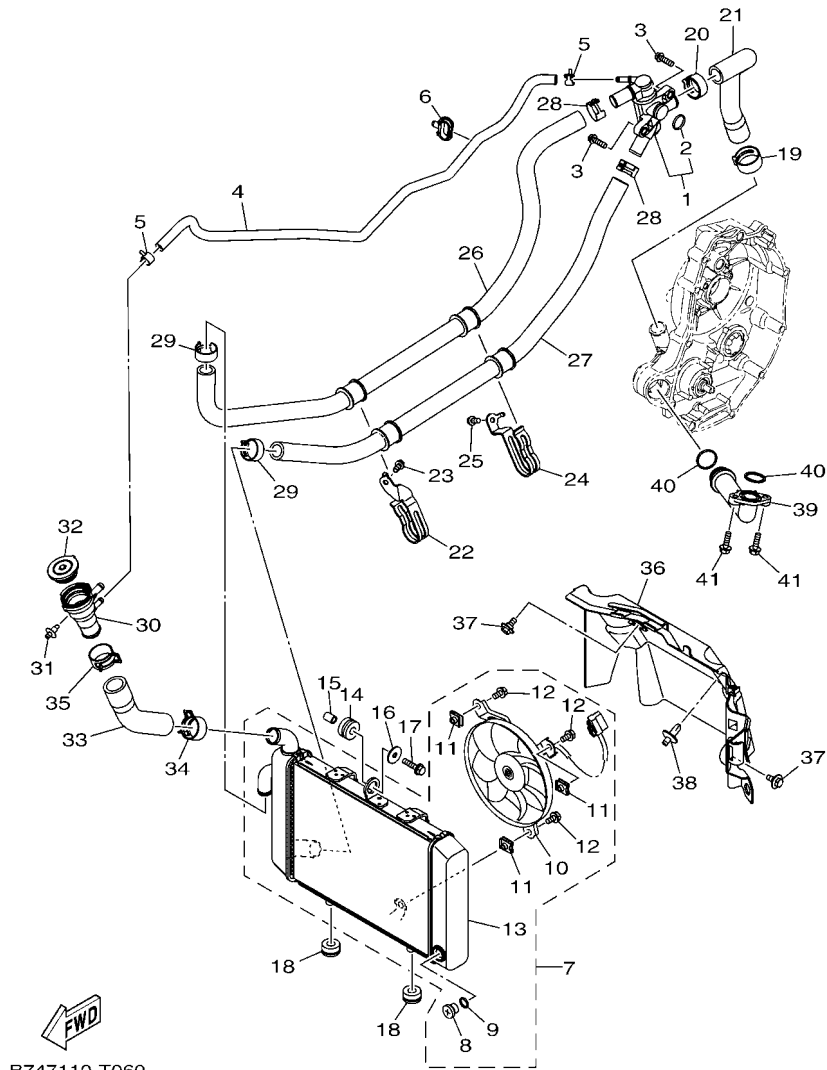

B747110-T060

REF. NO.	PART NO.	DESCRIPTION	B74C				REMARKS
1	B74-12410-00	THERMOSTAT ASSY	1				
2	52S-12439-00	.O-RING	1				
3	95022-06020	BOLT, FLANGE	2				
4	B74-E2576-00	HOSE 1	1				
5	90467-10038	CLIP	2				
6	90464-10802	CLAMP	1				
7	B74-E240A-00	RADIATOR ASSY	1				
8	5ST-E2615-00	.COCK, DRAIN	1				
9	5ST-E2843-00	.O-RING	1				
10	B74-E2405-00	.BLOWER ASSY	1				
11	1WD-E2671-00	.NUT 1	3				
12	5GJ-12675-00	.BOLT, BLOWER HOLDING	3				
13	B74-E2461-00	.RADIATOR COMP	1				
14	90480-15483	GROMMET	1				
15	90387-064W3	COLLAR	1				
16	90201-06033	WASHER, PLATE	1				
17	95827-06025	BOLT, FLANGE	1				
18	90480-14818	GROMMET	2				
19	90467-22002	CLIP	1				
20	90467-24800	CLIP	1				
21	B74-E2481-00	PIPE 1	1				
22	B74-F1823-00	CLAMP, HOSE	1				
23	95022-06012	BOLT, FLANGE	1				
24	B74-F2591-00	CLAMP, HOSE	1				
25	95022-06012	BOLT, FLANGE	1				
26	B74-E2482-00	PIPE 2	1				
27	B74-E2483-00	PIPE 3	1				

FIG. 6 RADIATOR & HOSE

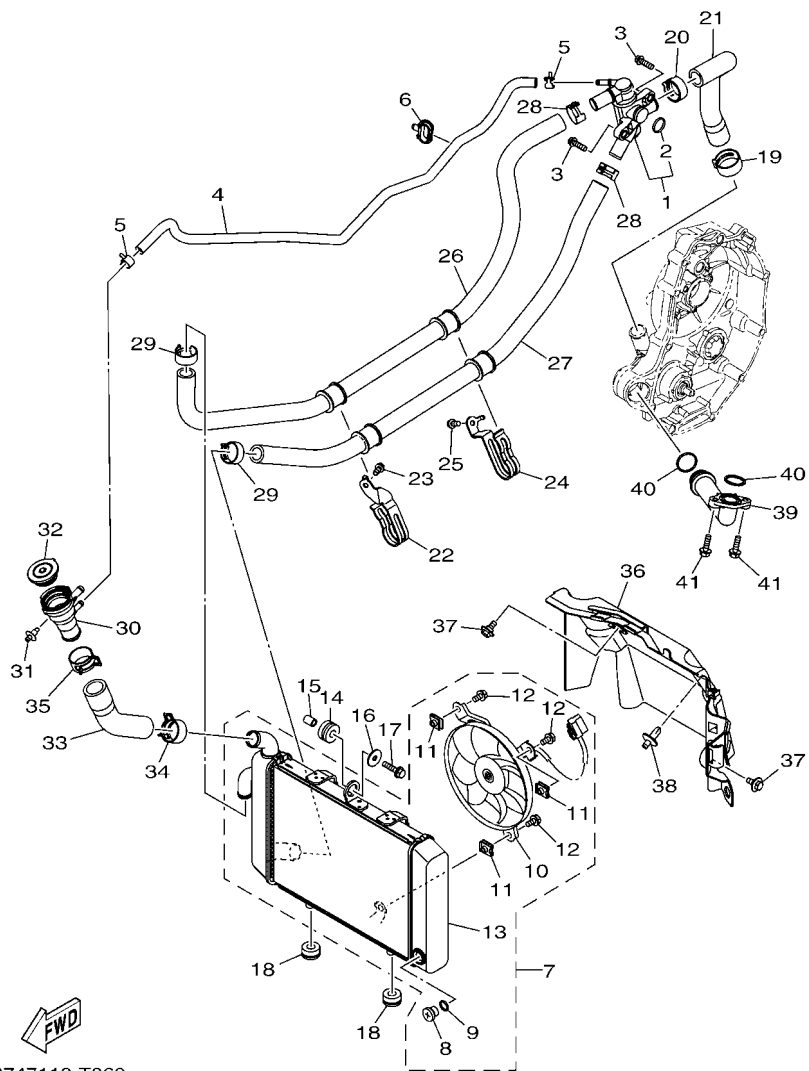

B747110-T060

REF. NO.	PART NO.	DESCRIPTION	B74C				REMARKS
28	90467-20805	CLIP	2				
29	90467-21801	CLIP	2				
30	B74-E2591-00	SUPT, FILLER NECK	1				
31	90269-07007	RIVET	1				
32	B65-E2462-00	CAP, RADIATOR	1				
33	B74-E2484-00	PIPE 4	1				
34	90467-250A1	CLIP	1				
35	90467-26131	CLIP	1				
36	B74-E2467-00	COVER, RADIATOR	1				
37	90109-06887	BOLT	2				
38	90269-06816	RIVET	1				
39	B74-E2446-00	JOINT	1				
40	93210-22800	O-RING	2				
41	95827-06020	BOLT, FLANGE	2				

FIG. 7 OIL PUMP

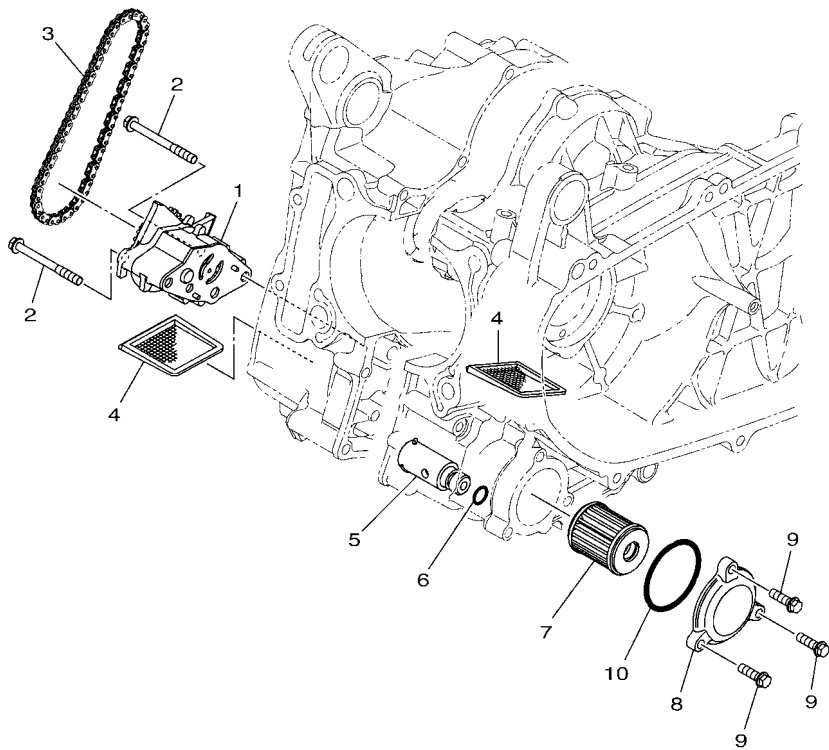

REF. NO.	PART NO.	DESCRIPTION	B74C				REMARKS
1	B74-E3300-00	OIL PUMP ASSY	1				
2	95022-06060	BOLT, FLANGE	2				
3	94568-F9058	CHAIN	1				
4	4ST-E3411-00	STRAINER, OIL	2				
5	5RU-13490-00	RELIEF VALVE ASSY	1				
6	93210-10096	O-RING	1				
7	1S7-E3440-00	ELEMENT ASSY, OIL CLEANER	1				
8	B74-E3447-00	COVER, OIL ELEMENT	1				
9	95022-06020	BOLT, FLANGE	3				
10	93210-48530	O-RING	1				



B741300-S070

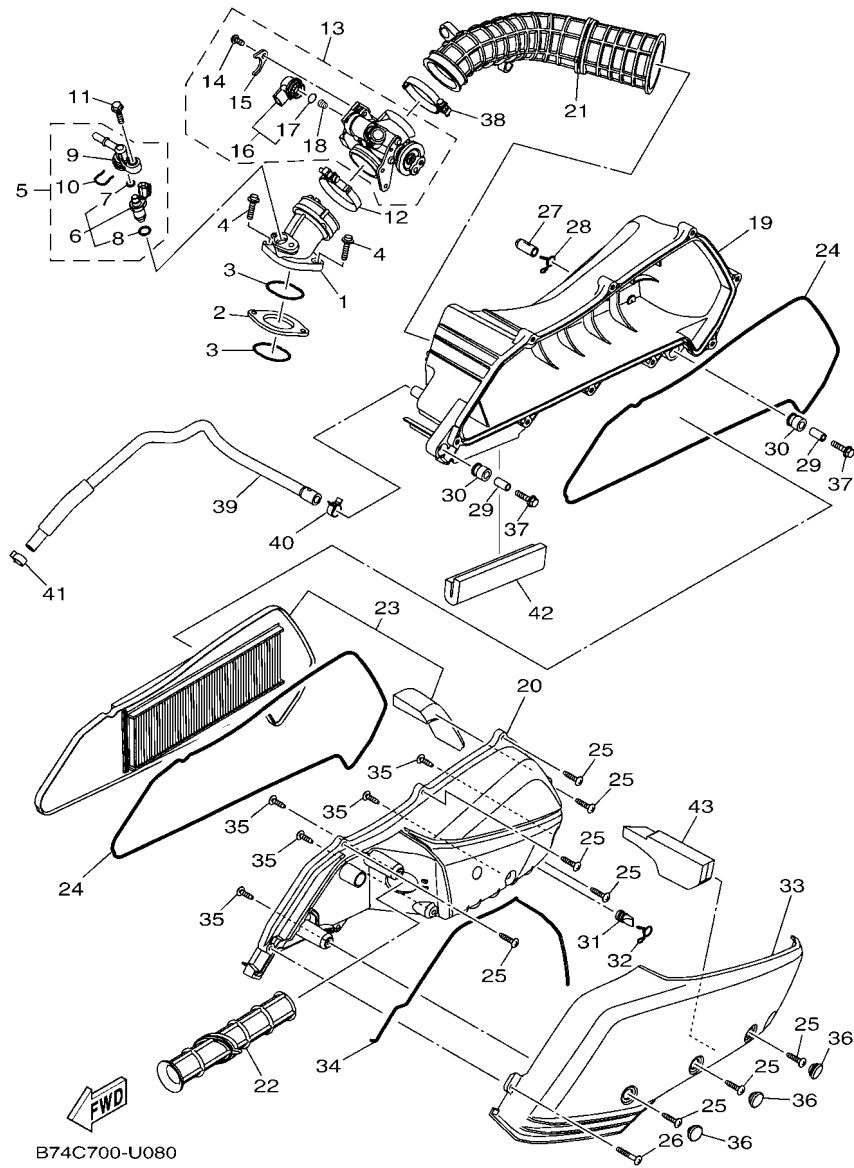

FIG. 8 INTAKE

REF. NO.	PART NO.	DESCRIPTION	B74C				REMARKS
1	B74-E3585-00	MANIFOLD	1				
2	B74-E3595-00	JOINT	1				
3	93210-40659	O-RING	2				
4	90110-06172	BOLT, HEXAGON SOCKET HEAD	2				
5	B74-E3770-00	INJECTOR ASSY	1				
6	B74-E3761-00	.INJECTOR	1				
7	54P-E4147-00	.O-RING	1				
8	5CA-E4147-00	.O-RING	1				
9	52S-13938-00	.PIPE	1				
10	54P-E4137-00	.CLIP	1				
11	95812-06025	BOLT, FLANGE	1				
12	90450-56009	HOSE CLAMP ASSY	1				
13	B74-E3750-01	THROTTLE BODY ASSY	1				
14	98502-06012	.SCREW, PAN HEAD	1				
15	54P-E4243-00	.PLATE	1				
16	B74-H5801-00	.STEPPING MOTOR	1				
17	54P-E416A-00	.O-RING	1				
18	B74-E4335-00	.SPRING, PLUNGER	1				
19	B74-E4411-00	CASE, AIR CLEANER 1	1				
20	B74-E4412-00	CAP, CLEANER CASE 1	1				
21	B74-E4469-00	FUNNEL, AIR	1				
22	B74-E4437-00	DUCT	1				
23	B74-WE445-00	AIR CLEANER ELEMENT ASSY	1				
24	B74-E4452-00	SEAL	2				
25	97707-50025	SCREW, TAPPING	8				
26	97707-50035	SCREW, TAPPING	1				
27	52B-E443E-00	PIPE, DRAIN	1				

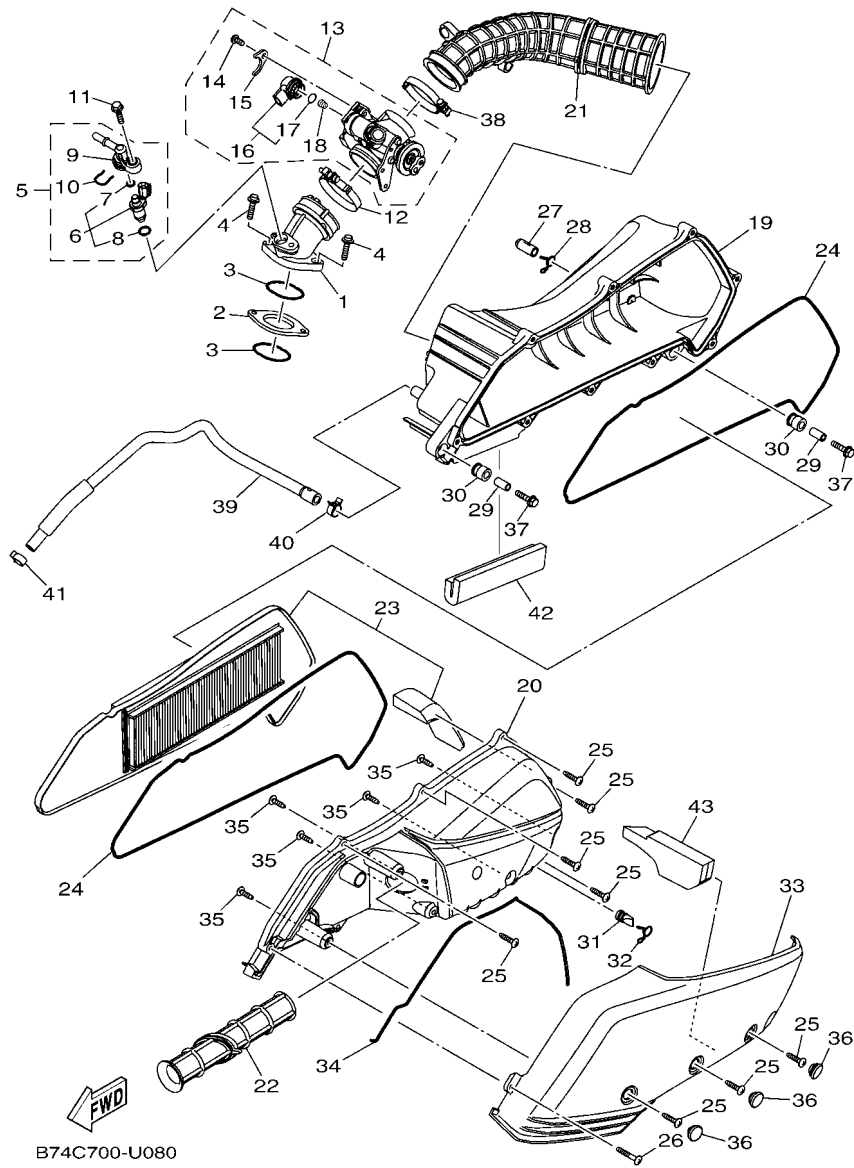
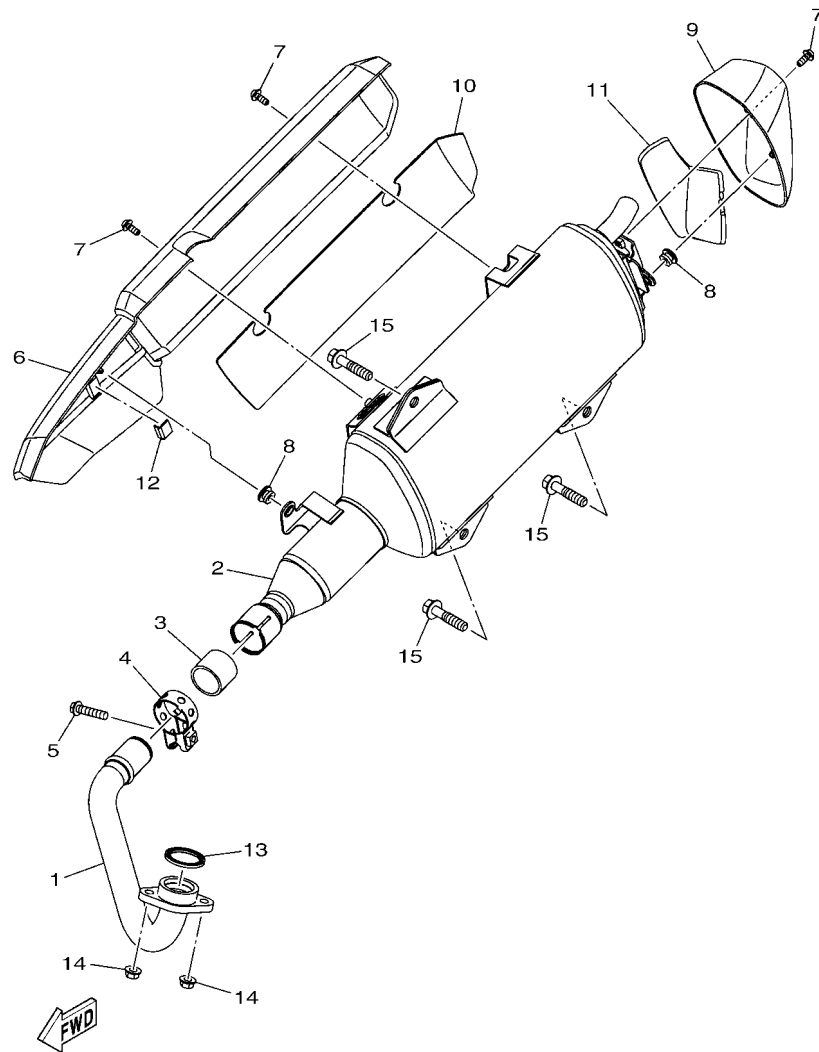

FIG. 8 INTAKE

REF. NO.	PART NO.	DESCRIPTION	B74C				REMARKS
28	90467-12809	CLIP	1				
29	B74-E4449-00	COLLAR	2				
30	B74-E4435-00	GROMMET	2				
31	5TP-E443G-10	PIPE, DRAIN 2	1				
32	90467-12809	CLIP	1				
33	B74-E4417-00	COVER 1	1				
34	B74-E4462-00	SEAL	1				
35	97702-50020	SCREW, TAPPING	5				
36	90338-14802	PLUG	3				
37	95812-06030	BOLT, FLANGE	2				
38	90450-52008	HOSE CLAMP ASSY	1				
39	B74-E1166-00	PIPE, BREATHER 1	1				
40	90467-13808	CLIP	1				
41	90467-14807	CLIP	1				
42	90520-10836	DAMPER, PLATE	1				
43	B74-E447F-00	ELEMENT 3	1				



B741300-S090

FIG. 9 EXHAUST

REF. NO.	PART NO.	DESCRIPTION	B74C				REMARKS
1	B74-E4611-00	PIPE, EXHAUST 1	1				
2	B74-E4711-00	MUFFLER 1	1				
3	54D-E4714-00	GASKET, MUFFLER	1				
4	1WD-E4715-00	BAND, MUFFLER	1				
5	95027-08035	BOLT, FLANGE	1				
6	B74-E4718-00	PROTECTOR, MUFFLER 1	1				
7	90111-06807	BOLT,HEX. SOCKET BUTTON	3				
8	90480-10332	GROMMET	2				
9	B74-E4799-00	CAP	1				
10	B74-E475P-00	SEAT	1				
11	B74-E476P-00	SEAT	1				
12	B74-E477P-00	SEAT	1				
13	1WD-E4613-00	GASKET, EXHAUST PIPE	1				
14	95702-08500	NUT, FLANGE	2				
15	95817-10045	BOLT, FLANGE	3				

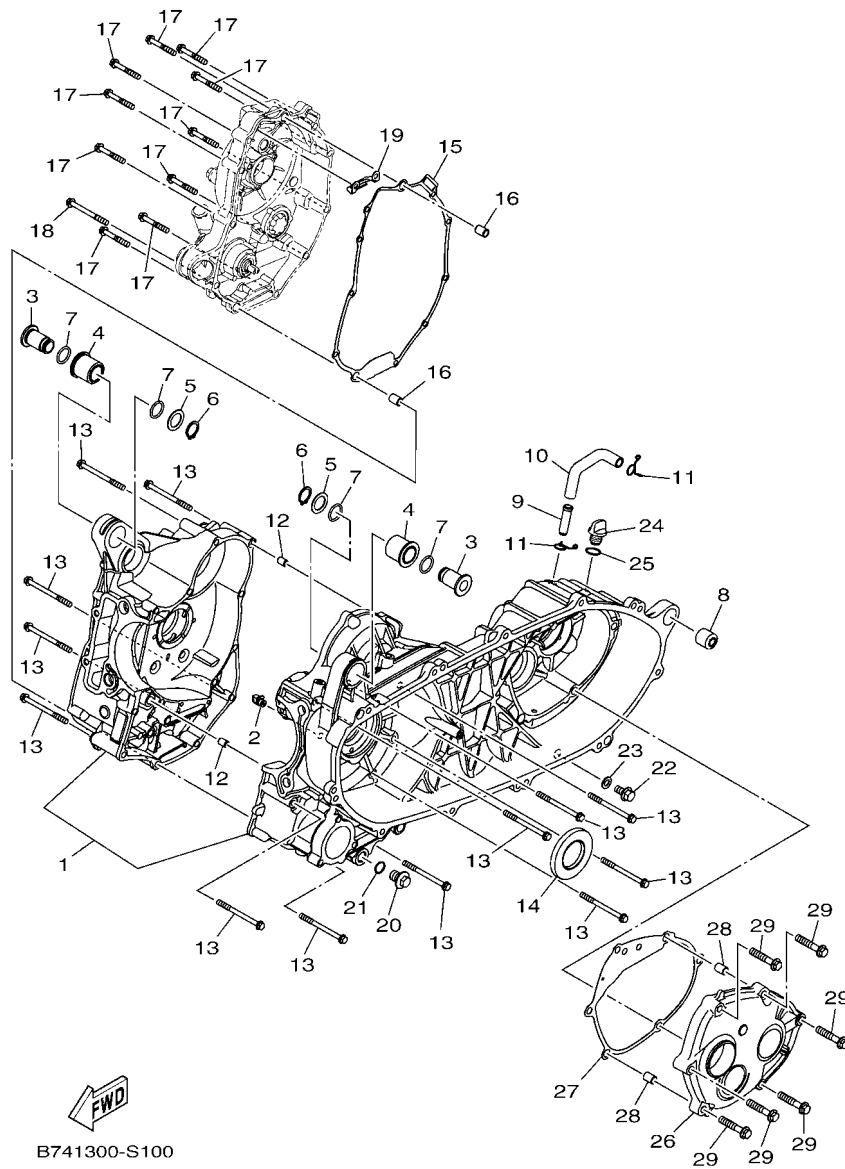

B741300-S100

FIG. 10 CRANKCASE

REF. NO.	PART NO.	DESCRIPTION	B74C	REMARKS
1	B74-E5150-00	CRANKCASE ASSY	1	
2	5D9-E5155-00	NOZZLE 3	1	
3	B74-E5372-00	COLLAR, UNION	2	
4	B74-E5378-00	HOLDER	2	
5	90201-18262	WASHER, PLATE	2	
6	99009-18400	CIRCLIP	2	
7	93210-18397	O-RING	4	
8	5MX-F2216-00	BUSH, REAR SHOCK ABSORBER	1	
9	40D-E1126-00	PIPE, BREATHER 3	1	
10	B74-E5373-00	PIPE, BREATHER	1	
11	90467-12052	CLIP	2	
12	99530-08012	PIN, DOWEL	2	
13	95022-06070	BOLT, FLANGE	13	
14	93102-35805	OIL SEAL	1	
15	B74-E5453-00	GASKET	1	
16	91810-14809	PIN, DOWEL	2	
17	95022-06040	BOLT, FLANGE	10	
18	95022-06060	BOLT, FLANGE	1	
19	2PV-E5113-00	PLATE	1	
20	90340-12808	PLUG, STRAIGHT SCREW	1	
21	4YS-E1198-00	GASKET	1	
22	95812-08016	BOLT, FLANGE	1	
23	90430-08119	GASKET	1	
24	5LW-E5363-00	PLUG, OIL	1	
25	93210-14816	O-RING	1	
26	B74-E5421-00	COVER, CRANKCASE 2	1	
27	B74-E5461-00	GASKET, CRANKCASE COVER 2	1	

FIG. 10 CRANKCASE

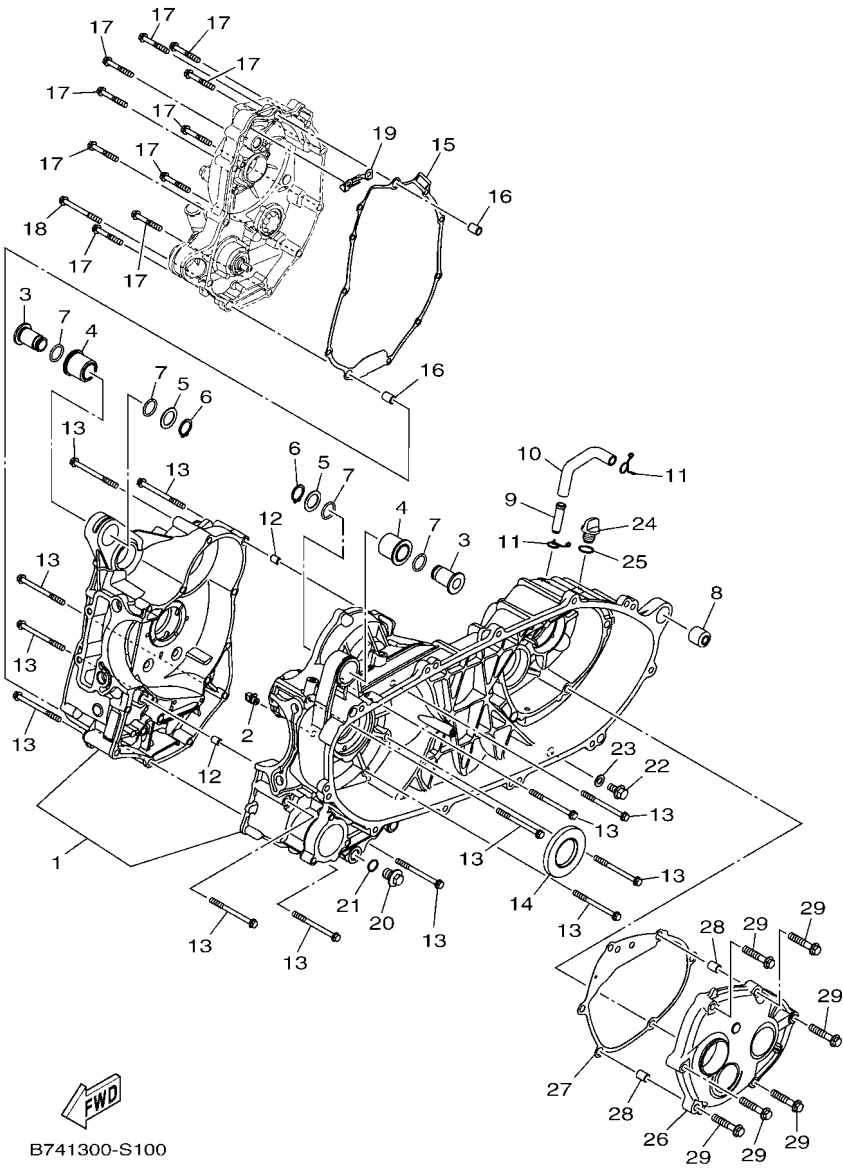

B741300-S100

REF. NO.	PART NO.	DESCRIPTION	B74C				REMARKS
28	91810-14809	PIN, DOWEL	2				
29	95022-08040	BOLT, FLANGE	6				
<hr/>							
<hr/>							
<hr/>							
<hr/>							
<hr/>							
<hr/>							
<hr/>							
<hr/>							

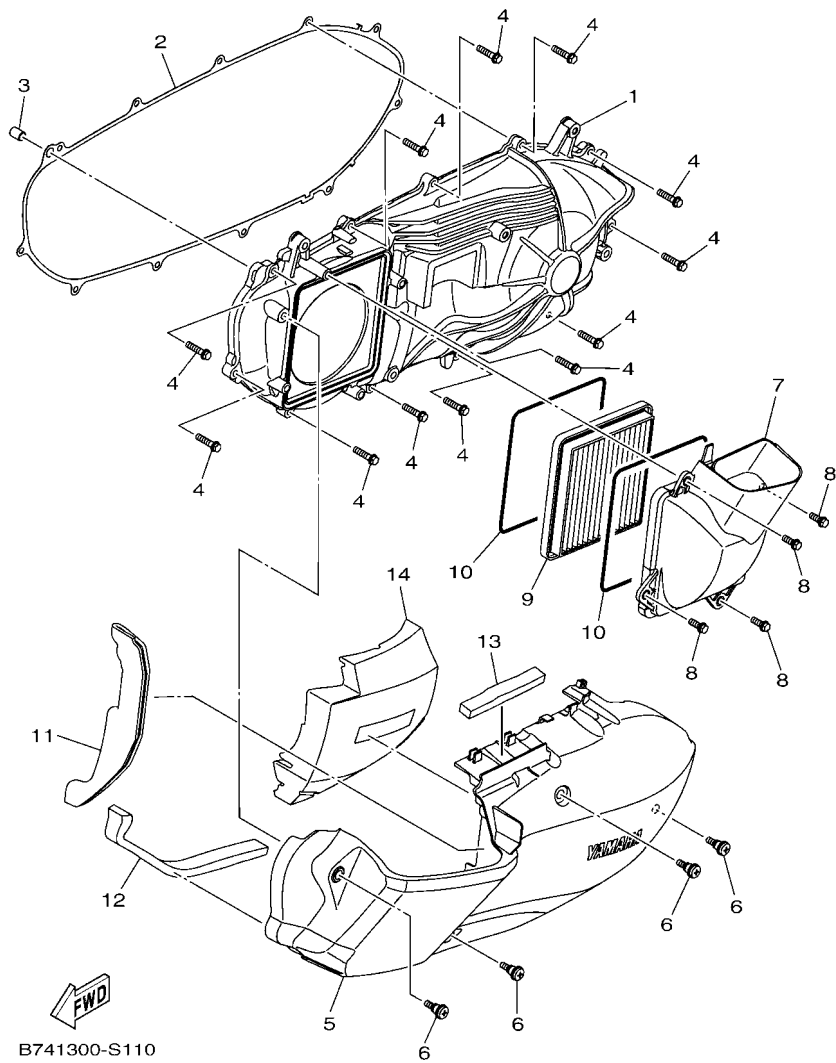

B741300-S110

FIG. 11 CRANKCASE COVER 1

REF. NO.	PART NO.	DESCRIPTION	B74C	REMARKS
1	B74-E5411-00	COVER, CRANKCASE 1	1	
2	B74-E5451-00	GASKET, CRANKCASE COVER 1	1	
3	91810-14809	PIN, DOWEL	1	
4	95022-06025	BOLT, FLANGE	12	
5	B74-E5431-00	COVER, CRANKCASE 3	1	
6	2DP-E5481-00	BOLT 1	4	
7	B74-E5471-00	DUCT, AIR	1	
8	95027-06016	BOLT, FLANGE	4	
9	B74-E5407-00	ELEMENT 1	1	
10	B74-E5474-00	SEAL, AIR DUCT	2	
11	90520-10837	DAMPER, PLATE	1	
12	90520-20821	DAMPER, PLATE	1	
13	90520-10835	DAMPER, PLATE	1	
14	B74-15338-00	DAMPER 5	1	

FIG. 12 STARTER

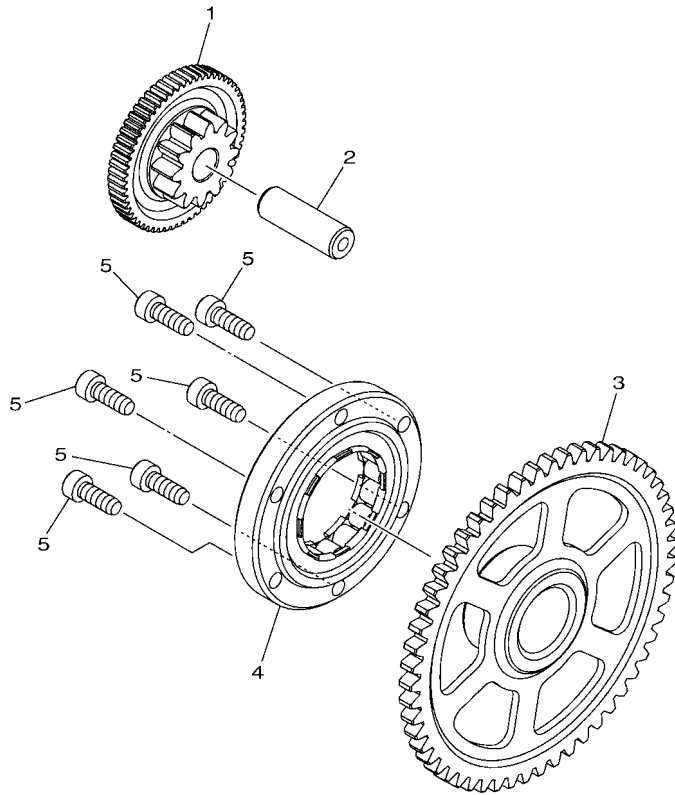

REF. NO.	PART NO.	DESCRIPTION	B74C				REMARKS
1	B74-E5512-00	GEAR, IDLER 1	1				
2	5BP-E5521-00	SHAFT 1	1				
3	B74-E5524-00	WHEEL, STARTER	1				
4	B74-E5590-00	STARTER ONE-WAY ASSY	1				
5	90110-06161	BOLT, HEXAGON SOCKET HEAD	6				

B741300-S120

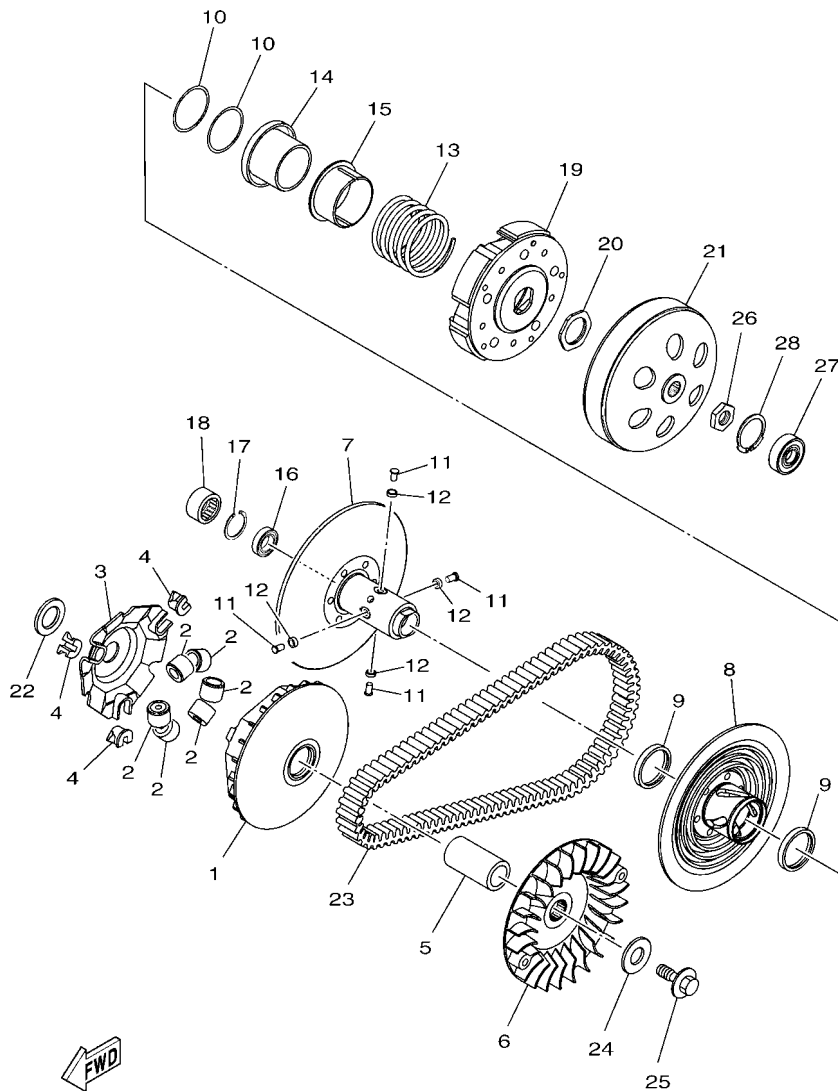

B741300-S130

FIG. 13 CLUTCH

REF. NO.	PART NO.	DESCRIPTION	B74C				REMARKS
1	B74-E7620-00	PRIMARY SLIDING SHEAVE COMP.	1				
2	B74-E7632-00	WEIGHT	6				
3	B74-E7623-00	CAM	1				
4	B74-E7653-00	SLIDER	3				
5	B74-E7674-00	COLLAR, GUIDE	1				
6	B74-E7611-00	SHEAVE, PRIMARY FIXED	1				
7	B74-E7660-00	SECONDARY FIXED SHEAVE COMP.	1				
8	B74-E7670-00	SECONDARY SLIDING SHEAVE	1				
9	B74-E7465-00	SEAL	2				
10	B74-E7465-10	SEAL	2				
11	B74-E7664-00	PIN, GUIDE	4				
12	B74-E7674-10	COLLAR, GUIDE	4				
13	B74-E7683-00	SPRING, SECONDARY	1				
14	B74-E7684-00	SEAT, SECONDARY SPRING	1				
15	B74-E7644-00	SEAT, SPRING	1				
16	B74-E7678-01	BEARING	1				
17	B74-E5744-00	CIRCLIP	1				
18	B74-E7678-10	BEARING	1				
19	B74-E6620-00	CLUTCH CARRIER ASSY	1				
20	B74-E7668-00	NUT	1				
21	B74-E6611-00	CLUTCH HOUSING COMP.	1				
22	90201-23015	WASHER, PLATE	1				
23	B74-E7641-00	V-BELT	1				
24	90201-19014	WASHER, PLATE	1				
25	90105-12807	BOLT, FLANGE	1				
26	90170-14802	NUT	1				
27	B74-E7412-00	BEARING	1				

FIG. 13 CLUTCH

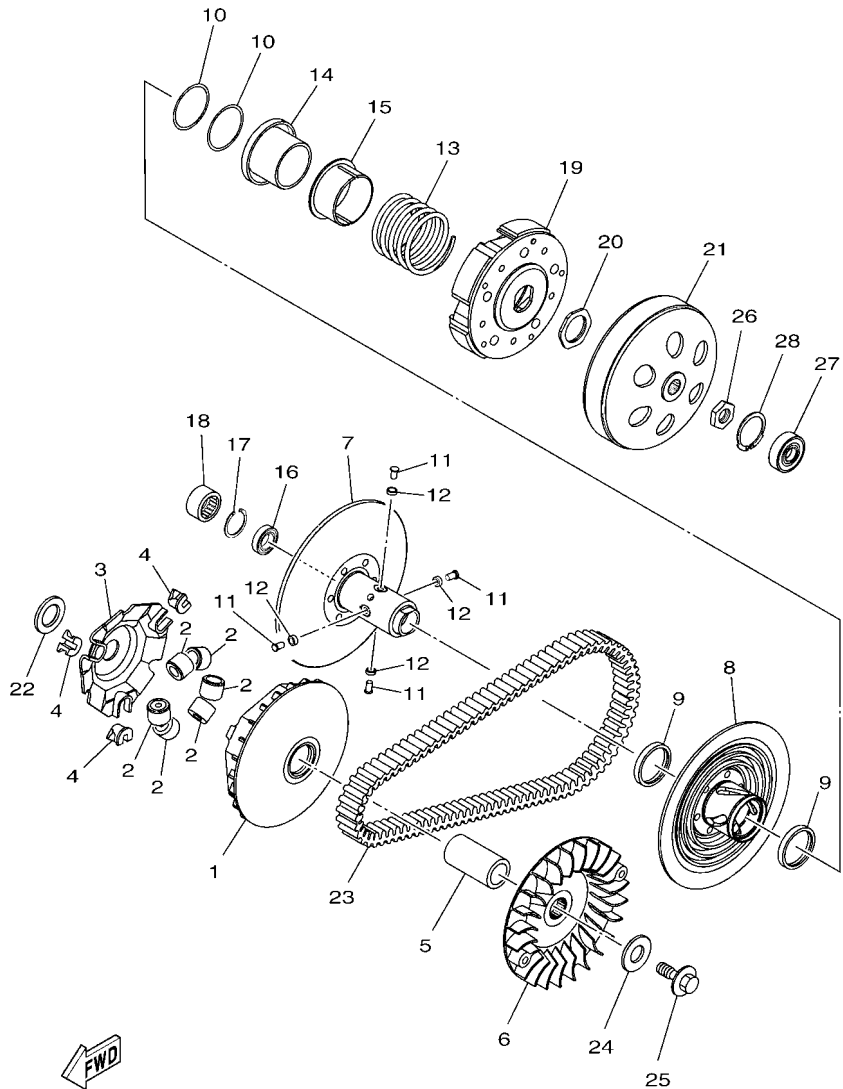

 B741300-S130

REF. NO.	PART NO.	DESCRIPTION	B74C				REMARKS
28	99009-40700	CIRCLIP	1				

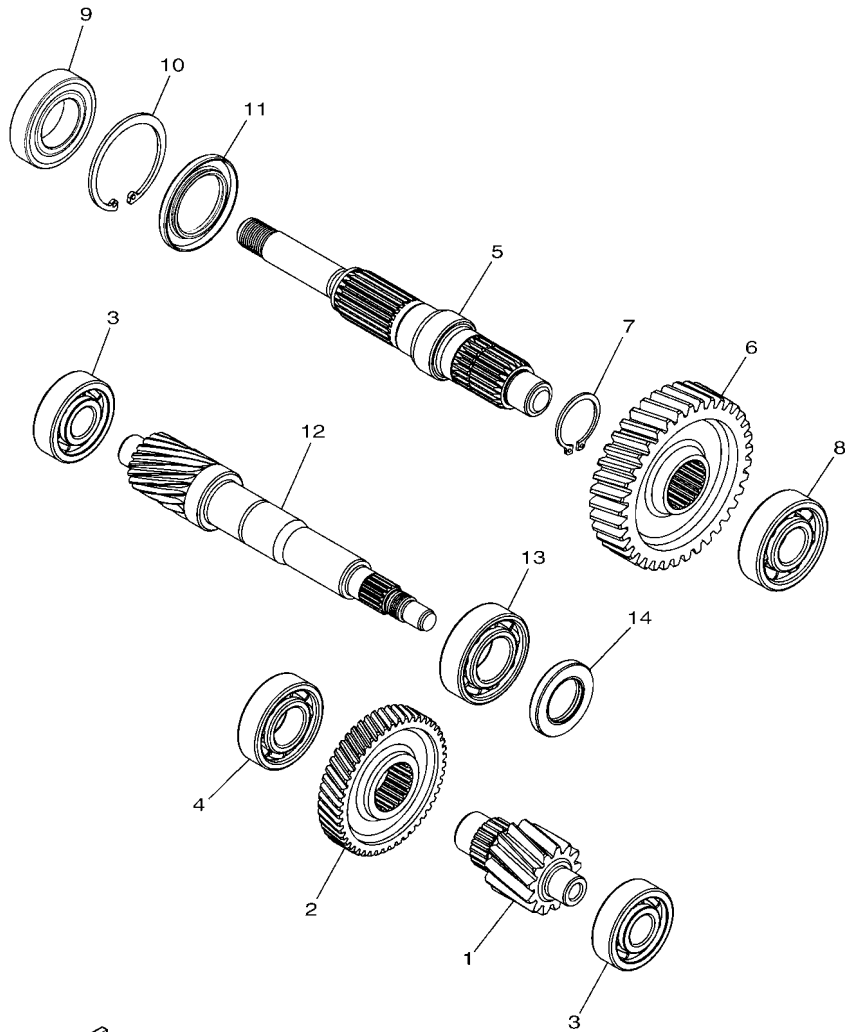

B741300-S140

FIG. 14 TRANSMISSION

REF. NO.	PART NO.	DESCRIPTION	B74C				REMARKS
1	B74-17411-00	AXLE, MAIN (13T)	1				
2	B74-E6151-00	GEAR, PRIMARY DRIVEN (48T)	1				
3	93306-303YT	BEARING	2				
4	93306-272YC	BEARING	1				
5	B74-E7421-00	AXLE, DRIVE	1				
6	B74-E7211-00	GEAR, 1ST WHEEL (37T)	1				
7	99009-28400	CIRCLIP	1				
8	93306-304YW	BEARING	1				
9	93306-078Y1	BEARING	1				
10	99009-52500	CIRCLIP	1				
11	93102-35806	OIL SEAL	1				
12	B74-E6111-00	GEAR, PRIMARY DRIVE (18D)	1				
13	93300-205Y0	BEARING	1				
14	93102-25826	OIL SEAL	1				

FIG. 15 FRAME

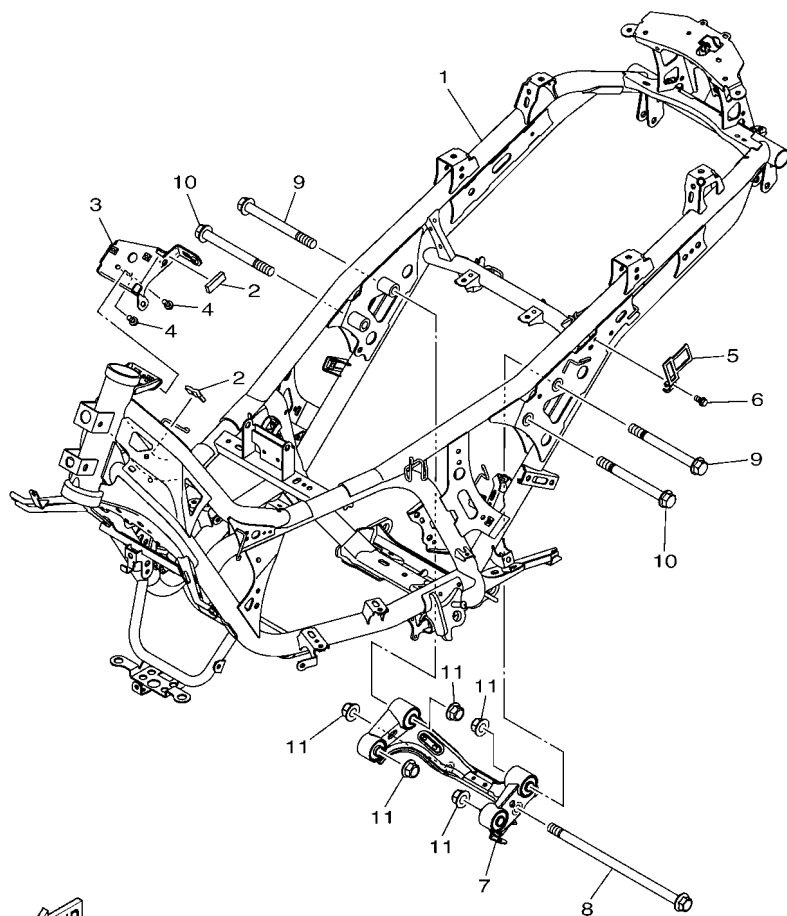

FWD
B741300-S150

REF. NO.	PART NO.	DESCRIPTION	B74C				REMARKS
1	B74-F1110-11	FRAME COMP.	1				
2	90520-04015	DAMPER, PLATE	2				
3	B74-H251P-00	BRACKET, MAIN SWITCH	1				
4	95022-06012	BOLT, FLANGE	2				
5	B74-F149S-00	BRACKET 5	1				
6	95022-06012	BOLT, FLANGE	1				
7	B74-F1400-01	ENGINE BRACKET COMP.	1				
8	B74-F2141-00	SHAFT, PIVOT	1				
9	90105-12806	BOLT, FLANGE	2				
10	90105-12805	BOLT, FLANGE	2				
11	95602-12200	NUT, SELF-LOCKING	5				

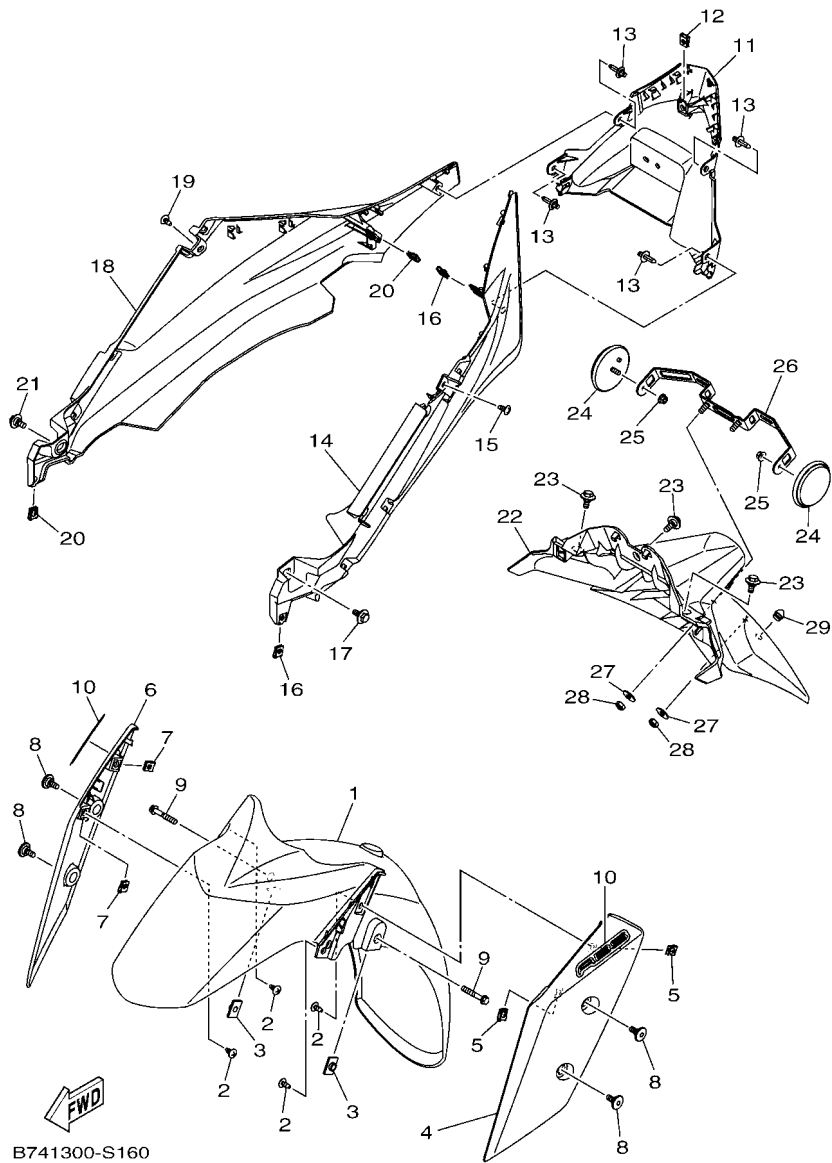

B741300-S160

FIG. 16 FENDER

REF. NO.	PART NO.	DESCRIPTION	B74C	REMARKS
1	B74-F1511-00	FENDER, FRONT	1	
2	97702-50012	SCREW, TAPPING	4	
3	90179-06055	NUT	2	
4	B74-F1513-00-P4	STAY, FENDER 1	1	UR FOR MBL2
	B74-F1513-00-P5	STAY, FENDER 1	1	UR FOR MS1
5	90183-05807	NUT, SPRING	2	
6	B74-F1514-00-P4	STAY, FENDER 2	1	UR FOR MBL2
	B74-F1514-00-P5	STAY, FENDER 2	1	UR FOR MS1
7	90183-05807	NUT, SPRING	2	
8	90109-068A4	BOLT	4	
9	95027-06035	BOLT, FLANGE	2	
10	BG6-F1578-00	EMBLEM	2	UR FOR MBL2
	BG6-F1578-10	EMBLEM	2	UR FOR MS1
11	B74-F1651-00	COVER, REAR FENDER	1	
12	90183-05807	NUT, SPRING	1	
13	90269-06816	RIVET	4	
14	B74-F172A-00	PANEL 1	1	
15	97702-50012	SCREW, TAPPING	1	
16	90183-05807	NUT, SPRING	2	
17	90109-06887	BOLT	1	
18	B74-F172F-00	PANEL 2	1	
19	97702-50012	SCREW, TAPPING	1	
20	90183-05807	NUT, SPRING	2	
21	90109-06887	BOLT	1	
22	B74-F1611-00	FENDER, REAR	1	
23	90109-06887	BOLT	3	
24	2FC-H5111-00	REFLECTOR, FRONT 1	2	

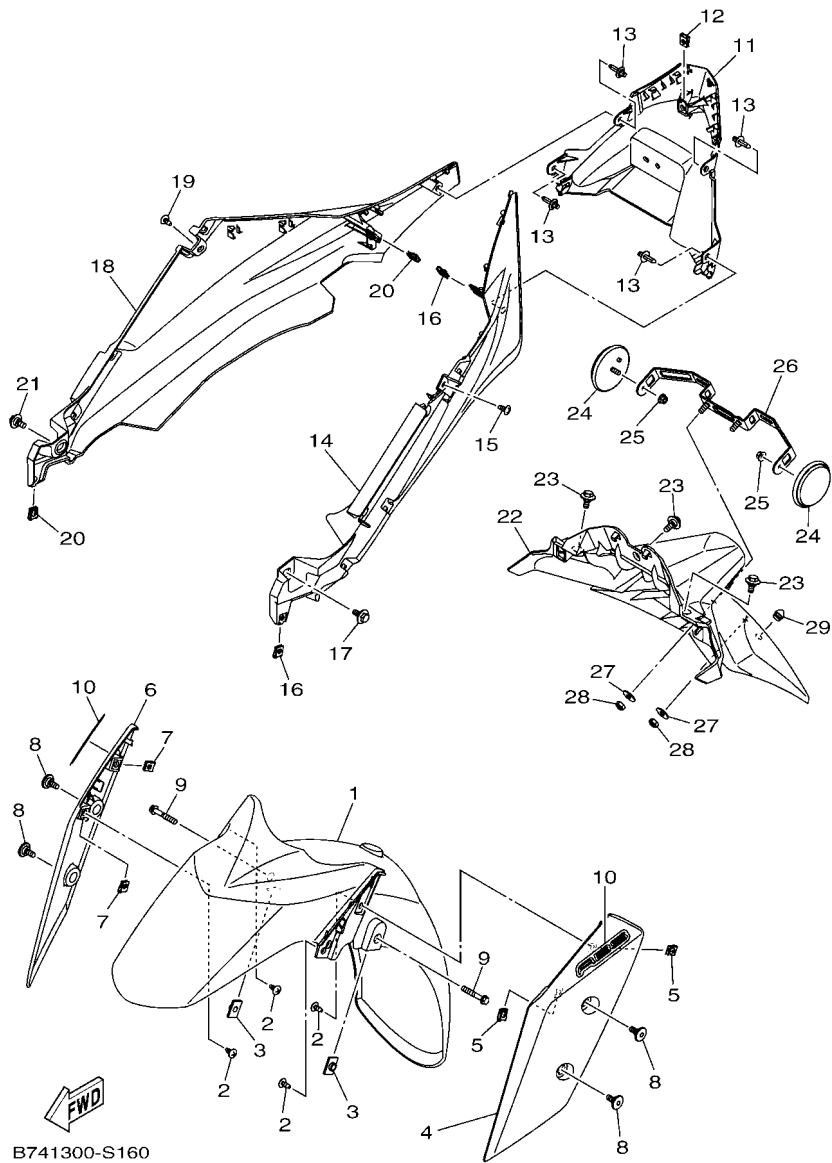

B741300-S160

FIG. 16 FENDER

REF. NO.	PART NO.	DESCRIPTION	B74C				REMARKS
25	95707-05500	NUT, FLANGE	2				
26	B74-H4550-00	LICENCE BRACKET ASSY	1				
27	90201-06088	WASHER, PLATE	2				
28	95602-06100	NUT, SELF-LOCKING	2				
29	4G0-21639-00	DAMPER 2	1				
<hr/>							
<hr/>							
<hr/>							
<hr/>							
<hr/>							
<hr/>							
<hr/>							
<hr/>							
<hr/>							
<hr/>							

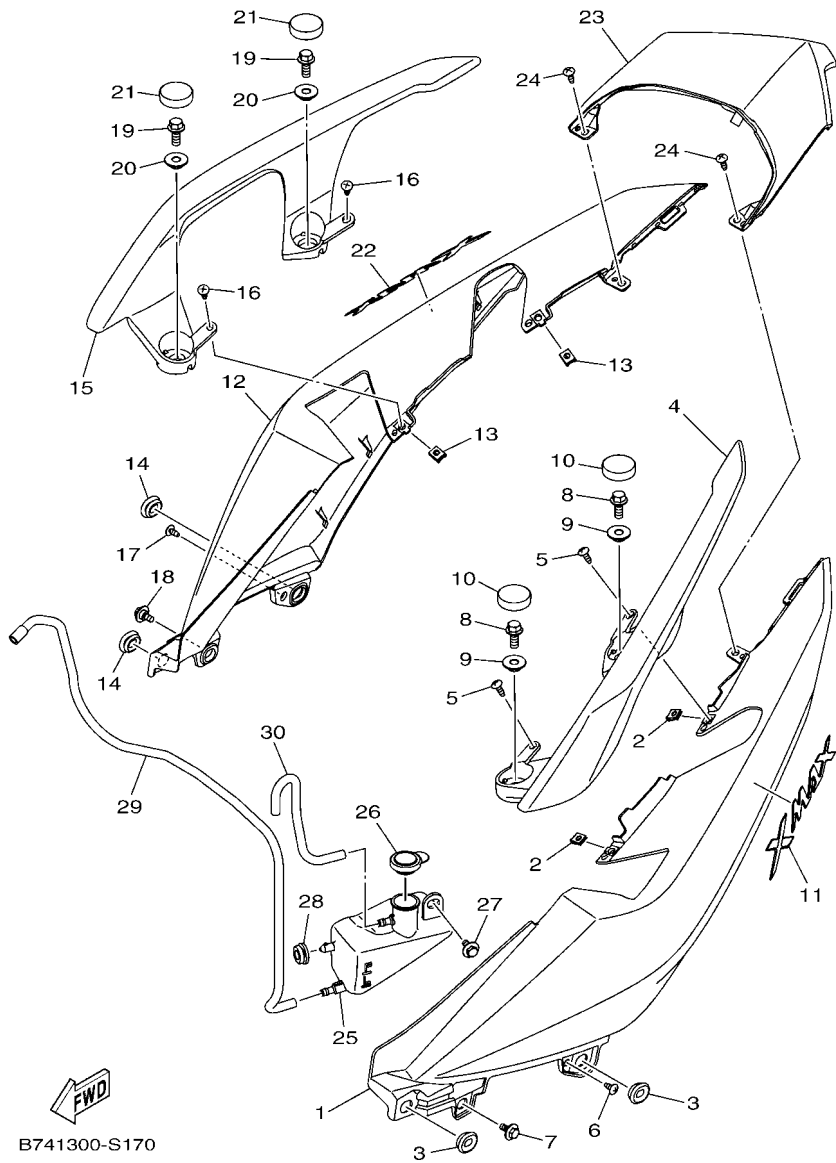

B741300-S170

FIG. 17 SIDE COVER

REF. NO.	PART NO.	DESCRIPTION	B74C	REMARKS
1	B74-F1731-00-P4	COVER, SIDE 3	1	UR FOR MBL2
	B74-F1731-00-P5	COVER, SIDE 3	1	UR FOR MS1
2	90183-05807	NUT, SPRING	2	
3	90480-01559	GROMMET	2	
4	B74-F474A-00-P4	ASSIST, GRIP	1	UR FOR MBL2
	B74-F474A-00-P5	ASSIST, GRIP	1	UR FOR MS1
5	97702-50016	SCREW, TAPPING	2	
6	97702-50012	SCREW, TAPPING	1	
7	90109-06887	BOLT	1	
8	95812-08020	BOLT, FLANGE	2	
9	90387-08839	COLLAR	2	
10	B74-F3469-00	CAP, BOLT	2	
11	B74-F173B-00	EMBLEM 3D	1	
12	B74-F1741-00-P4	COVER, SIDE 4	1	UR FOR MBL2
	B74-F1741-00-P5	COVER, SIDE 4	1	UR FOR MS1
13	90183-05807	NUT, SPRING	2	
14	90480-01559	GROMMET	2	
15	B74-F474W-00-P4	ASSIST,GRIP 2	1	UR FOR MBL2
	B74-F474W-00-P5	ASSIST,GRIP 2	1	UR FOR MS1
16	97702-50016	SCREW, TAPPING	2	
17	97702-50012	SCREW, TAPPING	1	
18	90109-06887	BOLT	1	
19	95812-08020	BOLT, FLANGE	2	
20	90387-08839	COLLAR	2	
21	B74-F3469-00	CAP, BOLT	2	
22	B74-F173B-00	EMBLEM 3D	1	
23	B74-F171E-00-P4	COVER, SIDE 5	1	UR FOR MBL2

FIG. 17 SIDE COVER

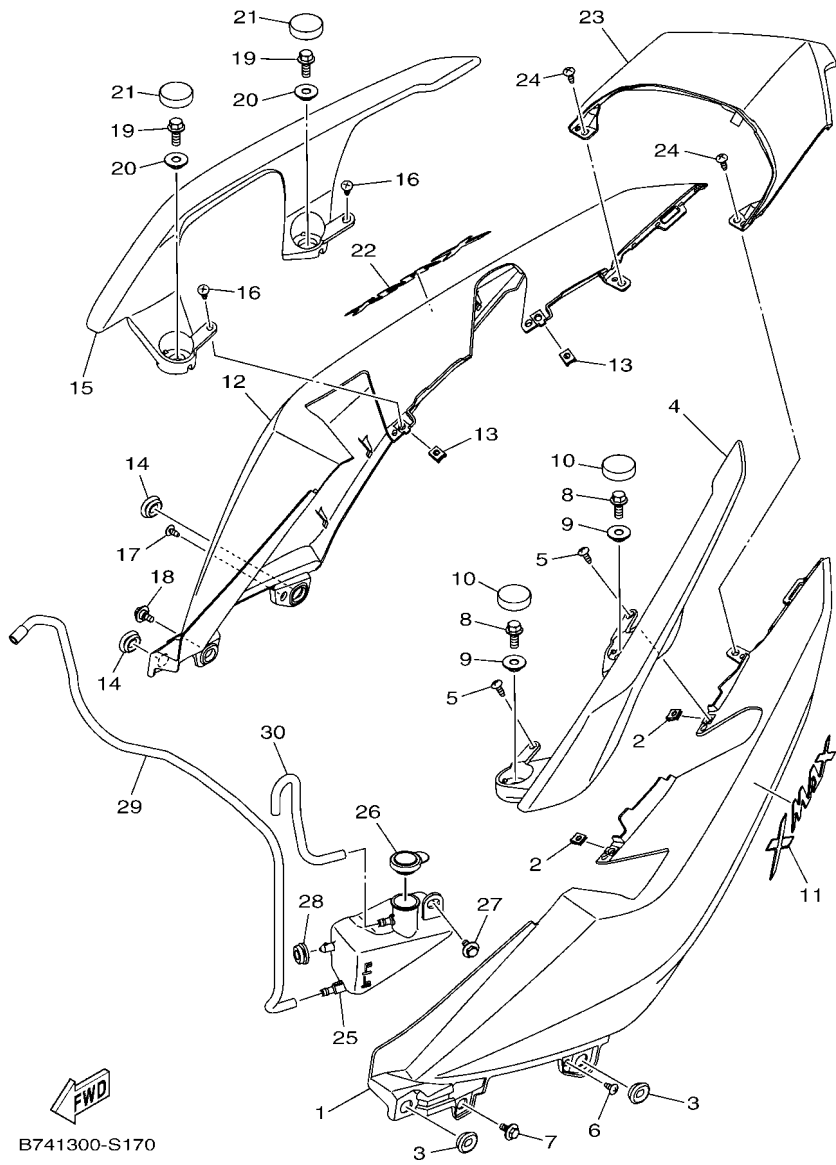

B741300-S170

REF. NO.	PART NO.	DESCRIPTION	B74C	REMARKS
23	B74-F171E-00-P5	COVER, SIDE 5	1	UR FOR MS1
24	97702-50016	SCREW, TAPPING	2	
25	B74-F1871-00	TANK, RECOVERY	1	
26	1S7-F1875-01	CAP	1	
27	90109-06887	BOLT	1	
28	90480-13567	GROMMET	1	
29	B74-F1816-00	PIPE 1	1	
30	B74-F1817-00	PIPE 2	1	

FIG. 18 REAR ARM & SUSPENSION

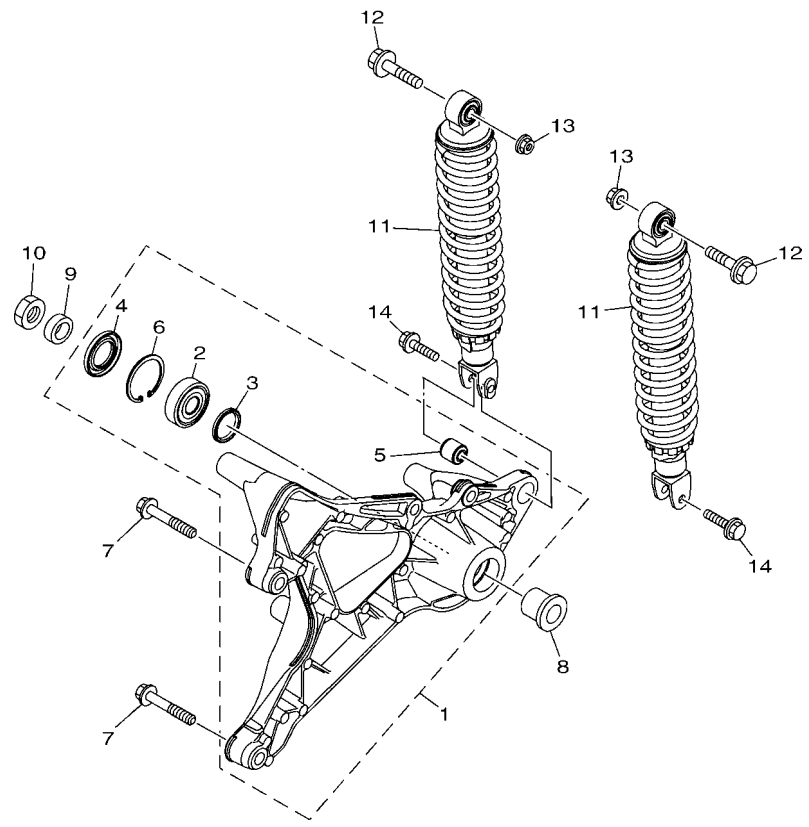

FWD
B741300-S180

REF. NO.	PART NO.	DESCRIPTION	B74C				REMARKS
1	B74-F2100-00	REAR ARM ASSY	1				
2	93306-303YV	.BEARING	1				
3	93106-28801	.OIL SEAL	1				
4	93106-28813	.OIL SEAL	1				
5	5MX-F2216-00	.BUSH, REAR SHOCK ABSORBER	1				
6	99009-47500	.CIRCLIP	1				
7	95812-10060	BOLT, FLANGE	2				
8	B74-F5183-00	COLLAR, WHEEL	1				
9	90387-17807	COLLAR	1				
10	90185-16800	NUT, SELF-LOCKING	1				
11	B74-F2210-00	SHOCK ABSORBER ASSY, REAR	2				
12	95817-10040	BOLT, FLANGE	2				
13	95602-10200	NUT, S/L FLANGE	2				
14	95817-08030	BOLT, FLANGE	2				

FIG. 19 STEERING

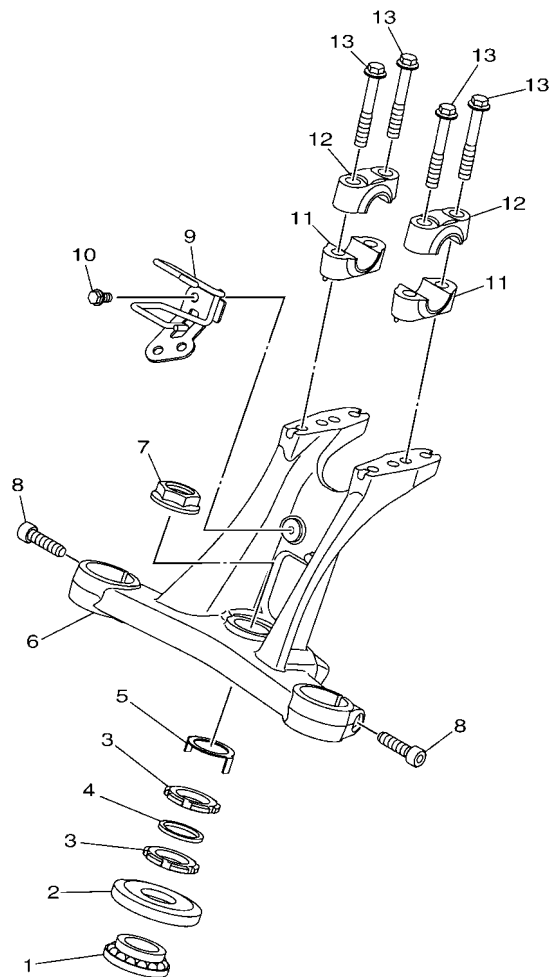

REF. NO.	PART NO.	DESCRIPTION	B74C				REMARKS
1	93399-999Y3	BEARING	1				
2	5BP-F3416-10	COVER, BALL RACE 2	1				
3	90179-25810	NUT	2				
4	90202-26142	WASHER, PLATE	1				
5	5BP-F3418-00	WASHER, SPECIAL	1				
6	B74-F3435-00	CROWN, HANDLE	1				
7	90179-22025	NUT	1				
8	91312-08030	BOLT, HEXAGON SOCKET HEAD	2				
9	B74-F312H-00	CLAMP	1				
10	95022-06012	BOLT, FLANGE	1				
11	B74-F3442-00	HOLDER, HANDLE LOWER	2				
12	B74-F3441-00	HOLDER, HANDLE UPPER	2				
13	95022-08055	BOLT, FLANGE	4				

B741300-S190

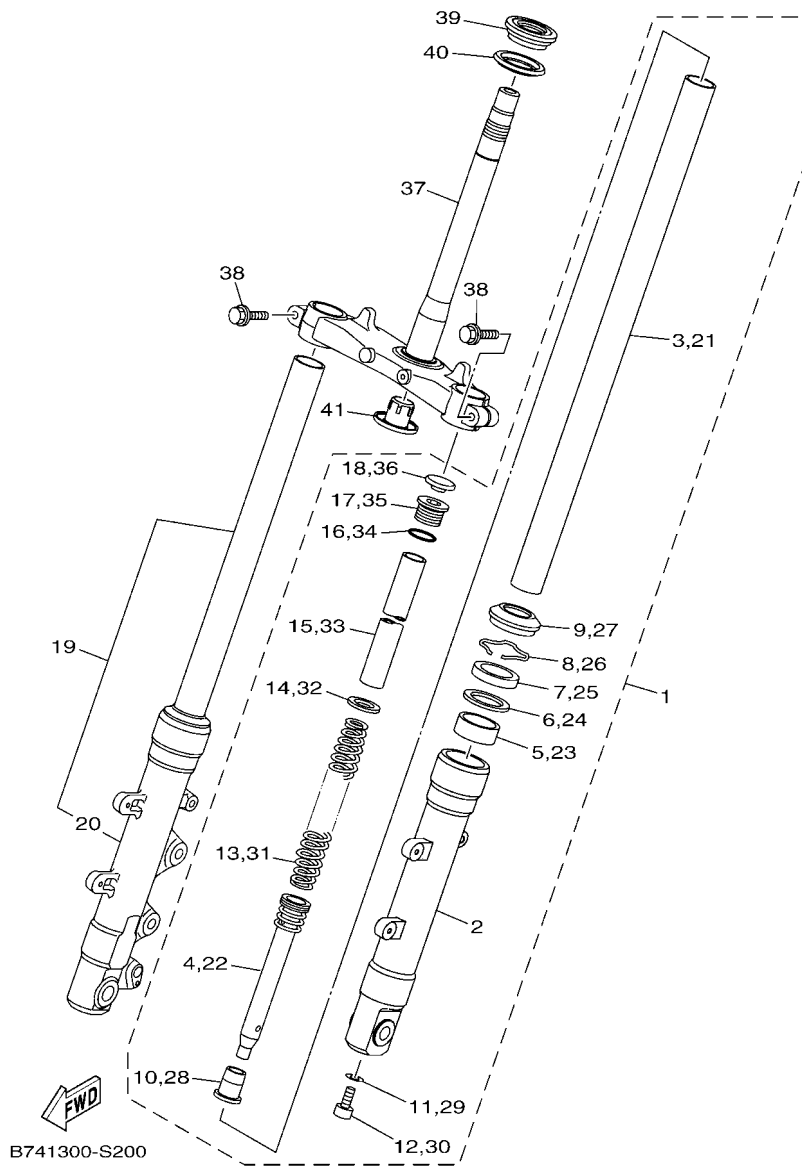
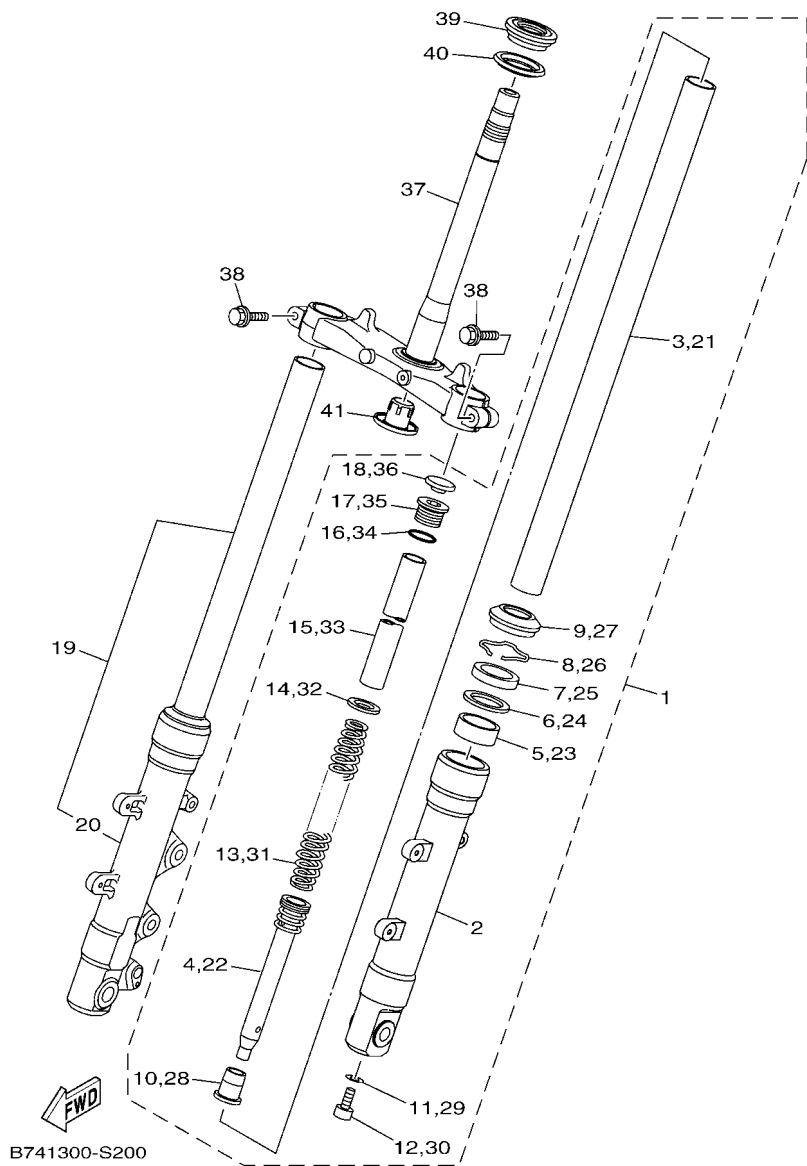

FIG. 20 FRONT FORK

REF. NO.	PART NO.	DESCRIPTION	B74C	REMARKS
1	B74-F3102-00	FRONT FORK ASSY (L.H)	1	
2	B74-F3126-00	.TUBE, OUTER (L.H)	1	
3	B74-F3110-00	.INNER TUBE COMP.1	1	
4	B74-F3170-00	.CYLINDER COMP., FRONT FORK	1	
5	4HC-23125-20	.METAL, SLIDE 1	1	
6	22W-23146-L0	.WASHER, OIL SEAL	1	
7	5BP-F3145-00	.OIL SEAL	1	
8	22W-F3156-L0	.RING, SNAP	1	
9	5BP-F3144-00	.SEAL, DUST	1	
10	2CM-F3166-00	.SPACER, OIL LOCK	1	
11	2BU-F3158-00	.GASKET	1	
12	31B-F3181-00	.BOLT, HEXAGON SOCKET HEAD	1	
13	B74-F3141-00	.SPRING, FRONT FORK	1	
14	2JK-F3149-01	.WASHER, SPRING UPPER	1	
15	B74-F3118-00	.SPACER	1	
16	2JK-F3114-00	.GASKET	1	
17	5BP-F3111-10	.BOLT, CAP	1	
18	2N4-23168-00	.PLUG	1	
19	B74-F3103-00	FRONT FORK ASSY (R.H)	1	
20	B74-F3136-00	.TUBE, OUTER 2	1	
21	B74-F3110-00	.INNER TUBE COMP.1	1	
22	B74-F3170-00	.CYLINDER COMP., FRONT FORK	1	
23	4HC-23125-20	.METAL, SLIDE 1	1	
24	22W-23146-L0	.WASHER, OIL SEAL	1	
25	5BP-F3145-00	.OIL SEAL	1	
26	22W-F3156-L0	.RING, SNAP	1	
27	5BP-F3144-00	.SEAL, DUST	1	

FIG. 20 FRONT FORK



REF. NO.	PART NO.	DESCRIPTION	B74C				REMARKS
28	2CM-F3166-00	.SPACER, OIL LOCK	1				
29	2BU-F3158-00	.GASKET	1				
30	31B-F3181-00	.BOLT, HEXAGON SOCKET HEAD	1				
31	B74-F3141-00	.SPRING, FRONT FORK	1				
32	2JK-F3149-01	.WASHER, SPRING UPPER	1				
33	B74-F3118-00	.SPACER	1				
34	2JK-F3114-00	.GASKET	1				
35	5BP-F3111-10	.BOLT, CAP	1				
36	2N4-23168-00	.PLUG	1				
37	B74-F3340-00	UNDER BRACKET COMP.	1				
38	2JK-F3346-00	BOLT 1	2				
39	93399-99932	BEARING	1				
40	3FV-23462-00	SEAL, STEERING	1				
41	B65-F3123-00	COVER, UNDER 1	1				

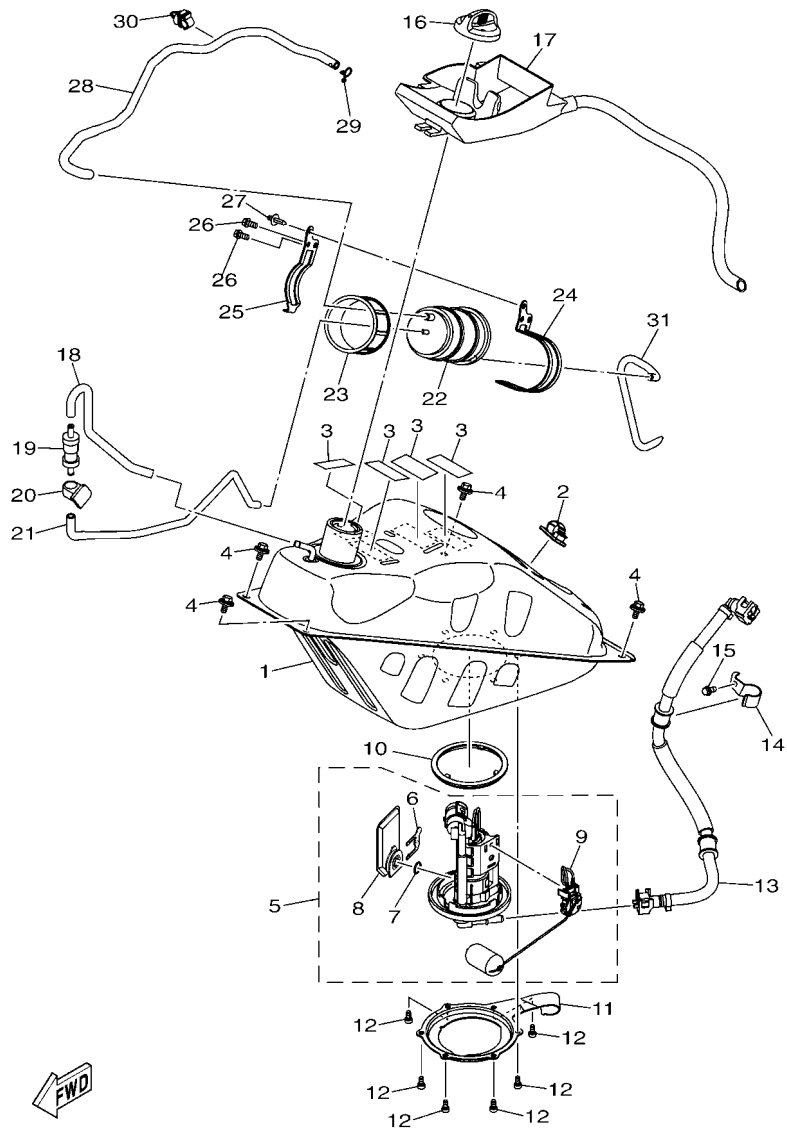

FWD
B741300-S210

FIG. 21 FUEL TANK

REF. NO.	PART NO.	DESCRIPTION	B74C				REMARKS
1	B74-F4110-01	FUEL TANK COMP.	1				
2	90464-13185	CLAMP	1				
3	5D9-F414G-00	SEAL	4				
4	90119-068A2	BOLT, WITH WASHER	4				
5	B74-E3907-00	FUEL PUMP COMP.	1				
6	3C1-F4519-00	.CLIP	1				
7	3C1-24512-00	.GASKET	1				
8	3C1-E3915-00	.FILTER	1				
9	B74-H5752-00	.SENDER UNIT ASSY, FUEL METER	1				
10	3C1-F4486-00	O-RING	1				
11	B74-F4425-00	BRACKET, FUEL PUMP 1	1				
12	91312-05010	BOLT, HEXAGON SOCKET HEAD	6				
13	B74-E3971-00	PIPE, FUEL 1	1				
14	B74-F419A-00	HOLDER	1				
15	95022-06012	BOLT, FLANGE	1				
16	B74-F4610-00	CAP ASSY	1				
17	B74-F414A-00	COVER, FILLER	1				
18	B74-F4313-00	PIPE 3	1				
19	1DW-F4180-02	ROLL OVER VALVE ASSY	1				
20	B74-F4135-00	CLAMP 1	1				
21	B74-F4314-00	PIPE 4	1				
22	B74-F4170-00	CANISTER ASSY	1				
23	B74-F483H-00	BAND	1				
24	B74-F452E-00	STAY	1				
25	B74-F454E-00	STAY 2	1				
26	95022-06012	BOLT, FLANGE	2				
27	90269-06816	RIVET	1				

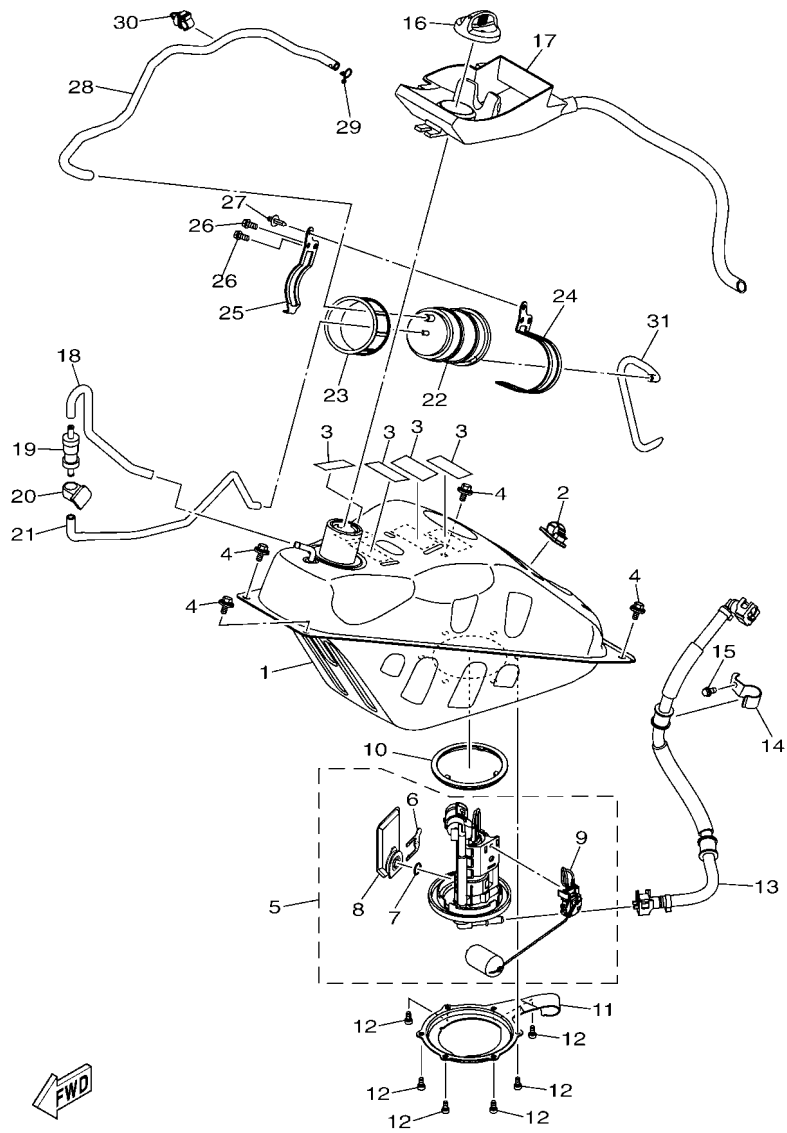

B741300-S210

FIG. 21 FUEL TANK

REF. NO.	PART NO.	DESCRIPTION	B74C				REMARKS
28	B74-F4315-00	PIPE 5	1				
29	90467-09006	CLIP	1				
30	90464-10008	CLAMP	1				
31	B74-F4316-00	PIPE 6	1				

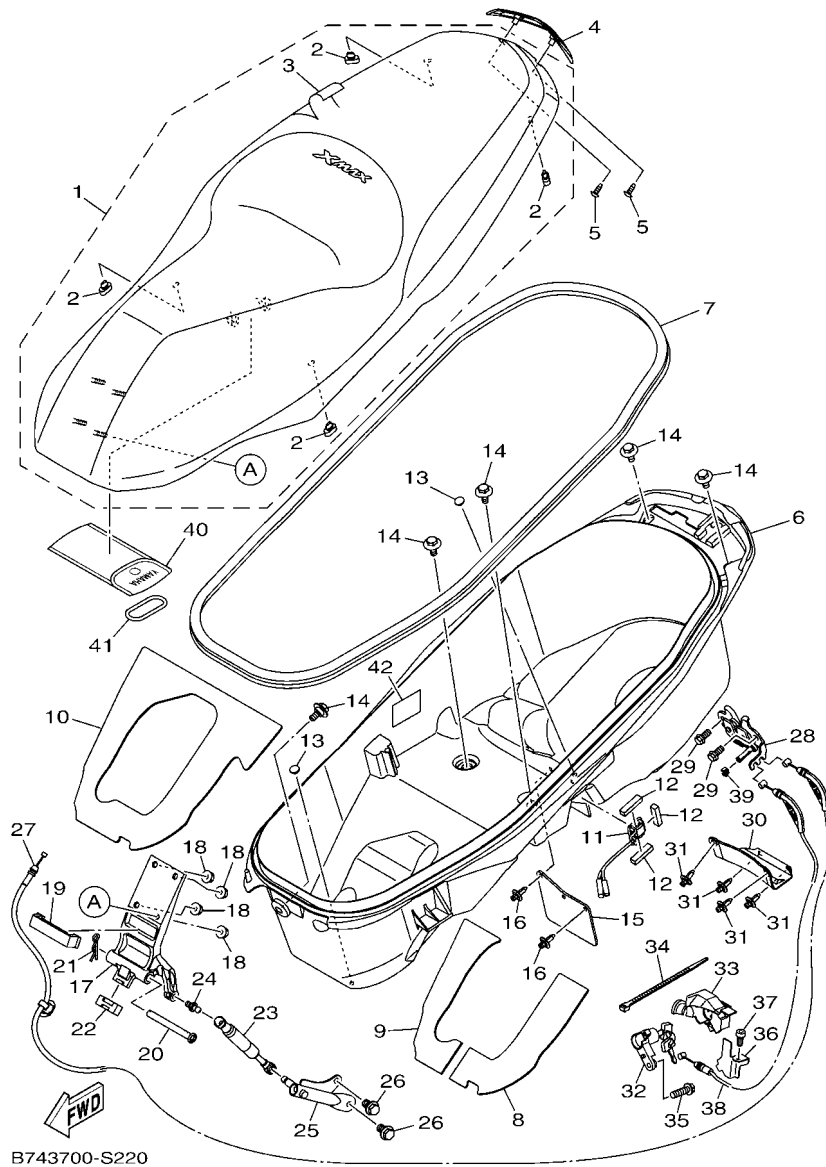

B743700-S220

FIG. 22 SEAT

REF. NO.	PART NO.	DESCRIPTION	B74C				REMARKS
1	B74-F4730-00	DOUBLE SEAT ASSY	1				
2	B74-F4741-00	.PAD, SEAT	4				
3	B74-F470F-00	.SEAT COVER COMP.	1				
4	B74-F4786-00	EMBLEM	1				
5	97702-40012	SCREW, TAPPING	2				
6	B74-F473R-00	BOX 1	1				
7	B74-F475M-00	SEAL	1				
8	B74-2476U-00	PROTECTOR 1	1				
9	B74-2476V-00	PROTECTOR,2	1				
10	B74-F4723-00	DAMPER, SEAT	1				
11	B74-H4770-00	LIGHT, ACCESSORY	1				
12	90520-10834	DAMPER, PLATE	3				
13	90338-06809	PLUG	2				
14	90109-06220	BOLT	5				
15	B74-F1621-00	FLAP	1				
16	90269-06816	RIVET	2				
17	B74-F4769-00	HINGE, SEAT	1				
18	95702-06500	NUT, FLANGE	4				
19	B74-F4785-00	MOLE, SEAT	1				
20	B74-F4727-00	PIN, SEAT FITTING	1				
21	90468-18121	CLIP	1				
22	B74-F4639-00	STOPPER, PLATE	1				
23	B74-F478G-00	STOPPER	1				
24	B74-F474E-00	ARM	1				
25	B74-F1121-00	BRACKET, DAMPER	1				
26	95022-08012	BOLT, FLANGE	2				
27	B74-F478E-00	CABLE, SEAT LOCK	1				

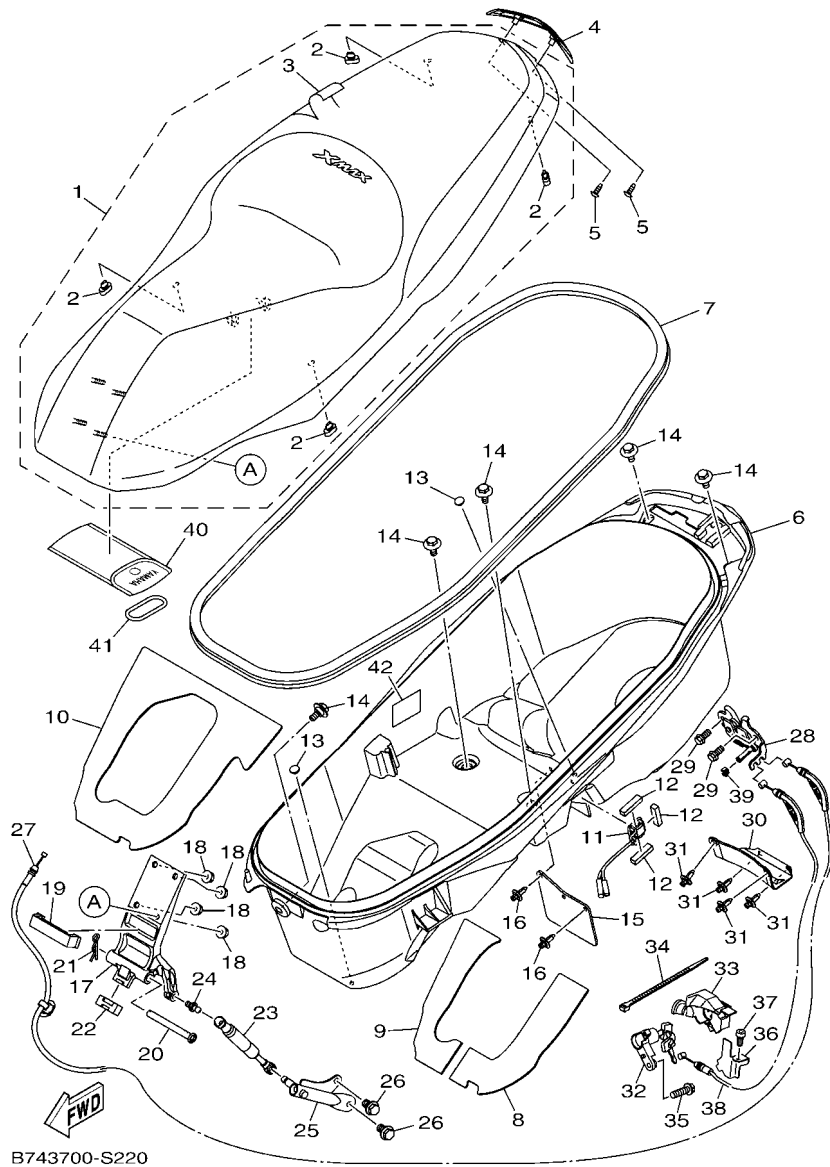

FIG. 22 SEAT

REF. NO.	PART NO.	DESCRIPTION	B74C				REMARKS
28	B65-F4780-00	SEAT LOCK ASSY	1				
29	95022-06012	BOLT, FLANGE	2				
30	B74-F472T-00	COVER, SEAT LOCK	1				
31	90269-06816	RIVET	4				
32	B74-F465E-00	ROTOR COMP.	1				
33	B74-F465B-00	CAP, ROTOR	1				
34	90464-36800	CLAMP	1				
35	92012-06020	BOLT, BUTTON HEAD	1				
36	B74-F471D-00	PLATE, LOCK 1	1				
37	91312-05010	BOLT, HEXAGON SOCKET HEAD	1				
38	B74-F479D-00	WIRE, SEAT LOCK 2	1				
39	1S7-F4768-00	STOPPER	1				
40	B74-F8100-00	TOOL KIT	1				
41	B74-F8175-00	HOLDER, TOOL	1				
42	1WD-F1668-01	LABEL, TIRE	1				

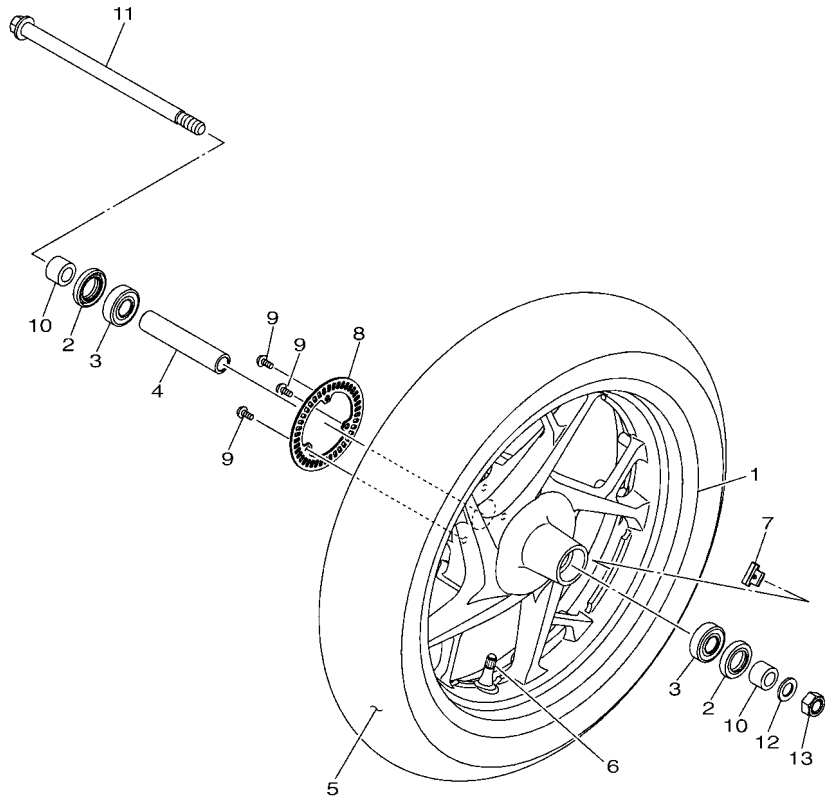
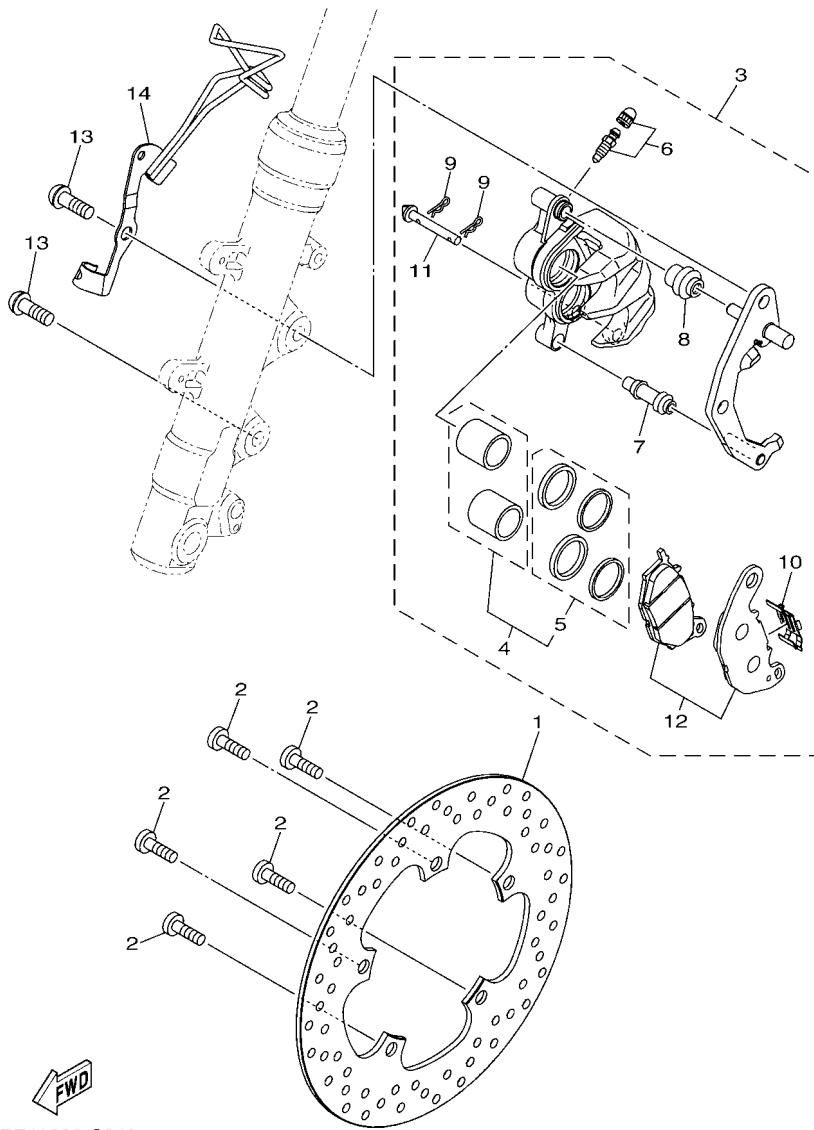

FIG. 23 FRONT WHEEL

REF. NO.	PART NO.	DESCRIPTION	B74C	REMARKS
1	B74-F5168-00-33	CAST WHEEL, FRONT	1	YB FOR MBL2,MS1
2	93106-22808	OIL SEAL	2	
3	933A6-202Y1	BEARING	2	
4	90387-15835	COLLAR	1	
5	94112-15800	TIRE (120/70-15 M/C 56P)	1	DUNLOP
6	93900-00828	VALVE, RIM	1	
7	5MT-25398-00	BALANCER, WHEEL (10G)	1	UN
	5MT-25398-10	BALANCER, WHEEL (20G)	1	UN
	5MT-25398-20	BALANCER, WHEEL (30G)	1	UN
8	2DP-F517G-00	ROTOR, SENSOR	1	
9	90149-05029	SCREW	3	
10	90387-15834	COLLAR	2	
11	B74-F5181-00	AXLE, WHEEL	1	
12	90201-15813	WASHER, PLATE	1	
13	90185-14801	NUT, SELF-LOCKING	1	

B741300-S230



B741300-S240

FIG. 24 FRONT BRAKE CALIPER

REF. NO.	PART NO.	DESCRIPTION	B74C				REMARKS
1	B74-F582U-00	DISK, BRAKE (RIGHT)	1				
2	90109-08232	BOLT	5				
3	B74-F580U-00	CALIPER ASSY (RIGHT)	1				
4	1WD-F5802-00	.PISTON ASSY, CALIPER	1				
5	1WD-F5803-00	..CALIPER SEAL KIT	1				
6	4C9-W0048-00	..BLEED SCREW KIT	1				
7	5YP-F5937-00	..BOOT 2	1				
8	5YP-F5917-00	..BOOT, CALIPER	1				
9	5YP-F5925-01	..CLIP	2				
10	1WD-F5919-00	..SUPPORT, PAD	1				
11	5YP-F5924-00	..PIN, PAD	1				
12	B74-F5805-00	..BRAKE PAD KIT	1				
13	90149-10804	SCREW	2				
14	B74-F3317-00	HOLDER, CABLE	1				

FIG. 25 REAR WHEEL

REF. NO.	PART NO.	DESCRIPTION	B74C				REMARKS
1	B74-F5338-00-33	CAST WHEEL, REAR	1				YB FOR MBL2,MS1
2	94114-14803	TIRE (140/70-14 M/C 62P)	1				DUNLOP
3	93900-00828	VALVE, RIM	1				
4	5MT-25398-00	BALANCER, WHEEL (10G)	1				UN
	5MT-25398-10	BALANCER, WHEEL (20G)	1				UN
	5MT-25398-20	BALANCER, WHEEL (30G)	1				UN
5	2DP-F517G-00	ROTOR, SENSOR	1				
6	90149-05029	SCREW	3				

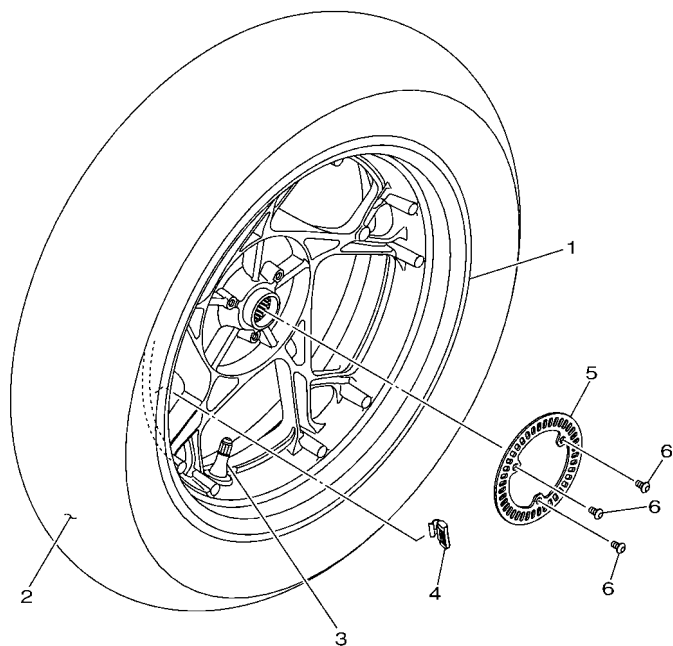

B741300-S250

FIG. 26 REAR BRAKE CALIPER

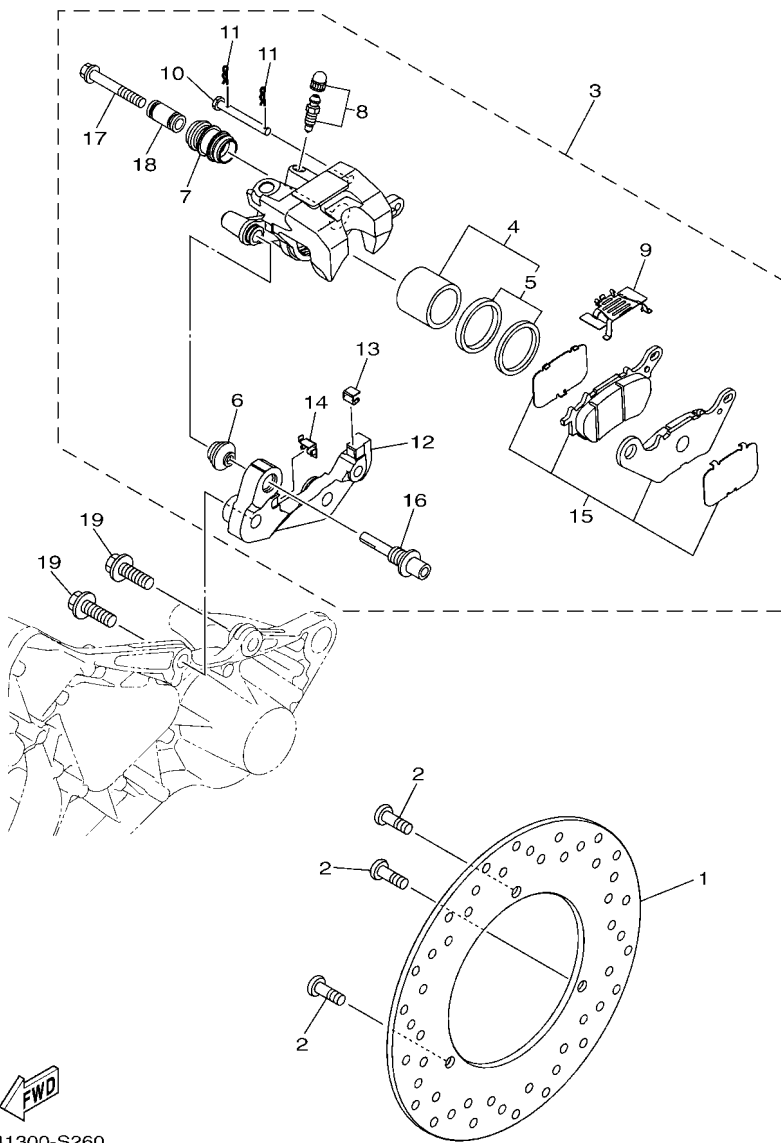

B741300-S260

REF. NO.	PART NO.	DESCRIPTION	B74C				REMARKS
1	B74-F582W-00	DISK, REAR BRAKE 2	1				
2	90111-08087	BOLT,HEX. SOCKET BUTTON	3				
3	B74-F580W-00	CALIPER ASSY, REAR 2	1				
4	1WD-F5802-50	.PISTON ASSY, CALIPER	1				
5	1WD-F5803-50	..CALIPER SEAL KIT	1				
6	5YP-F5917-00	.BOOT, CALIPER	1				
7	34X-25937-00	.BOOT 2	1				
8	5YP-W0048-50	.BLEED SCREW KIT	1				
9	B74-F5919-50	.SUPPORT, PAD	1				
10	1WD-F5924-50	.PIN, PAD	1				
11	5YP-F5925-01	.CLIP	2				
12	B74-F5921-50	.BRACKET, SUPPORT	1				
13	1WD-F5939-51	.CLIP, PAD	1				
14	1WD-F5939-61	.CLIP, PAD	1				
15	B74-F5806-00	.BRAKE PAD KIT 2	1				
16	1WD-F5914-50	.PIN, SLIDE	1				
17	5KN-25926-01	.BOLT	1				
18	5TL-F5838-00	.SLEEVE, CALIPER	1				
19	95812-10030	BOLT, FLANGE	2				

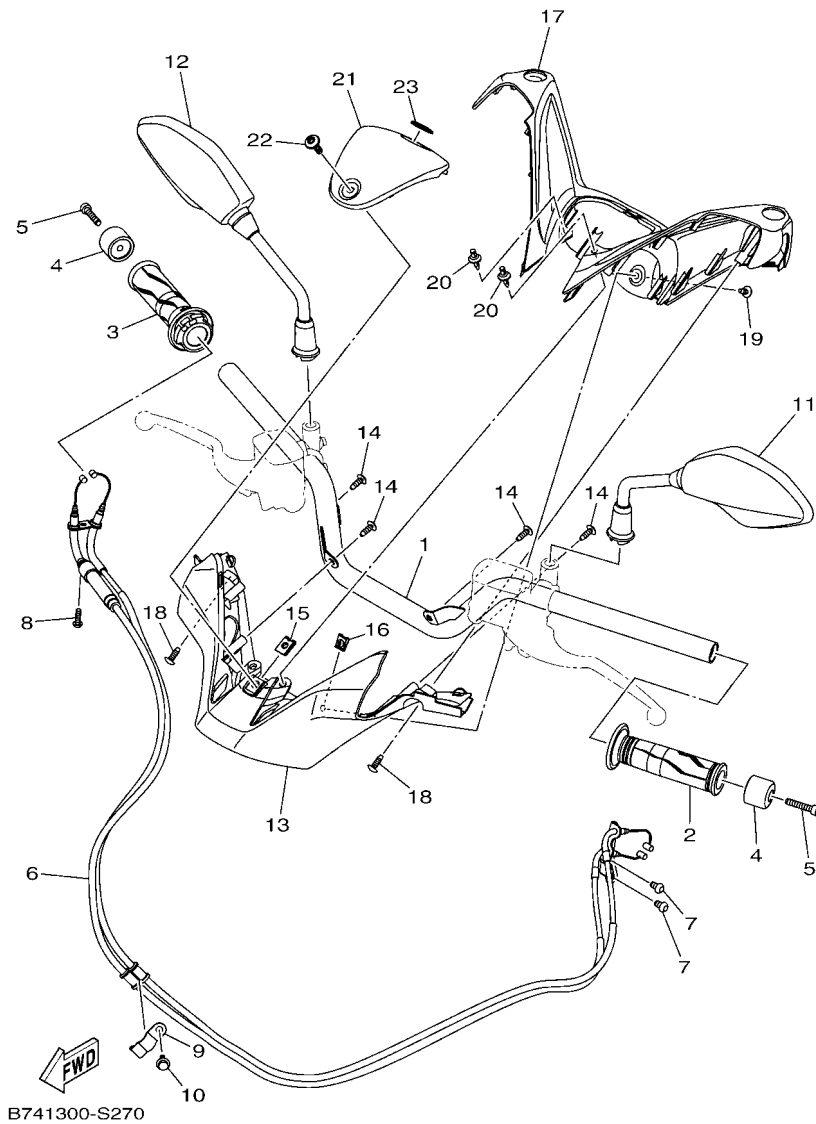
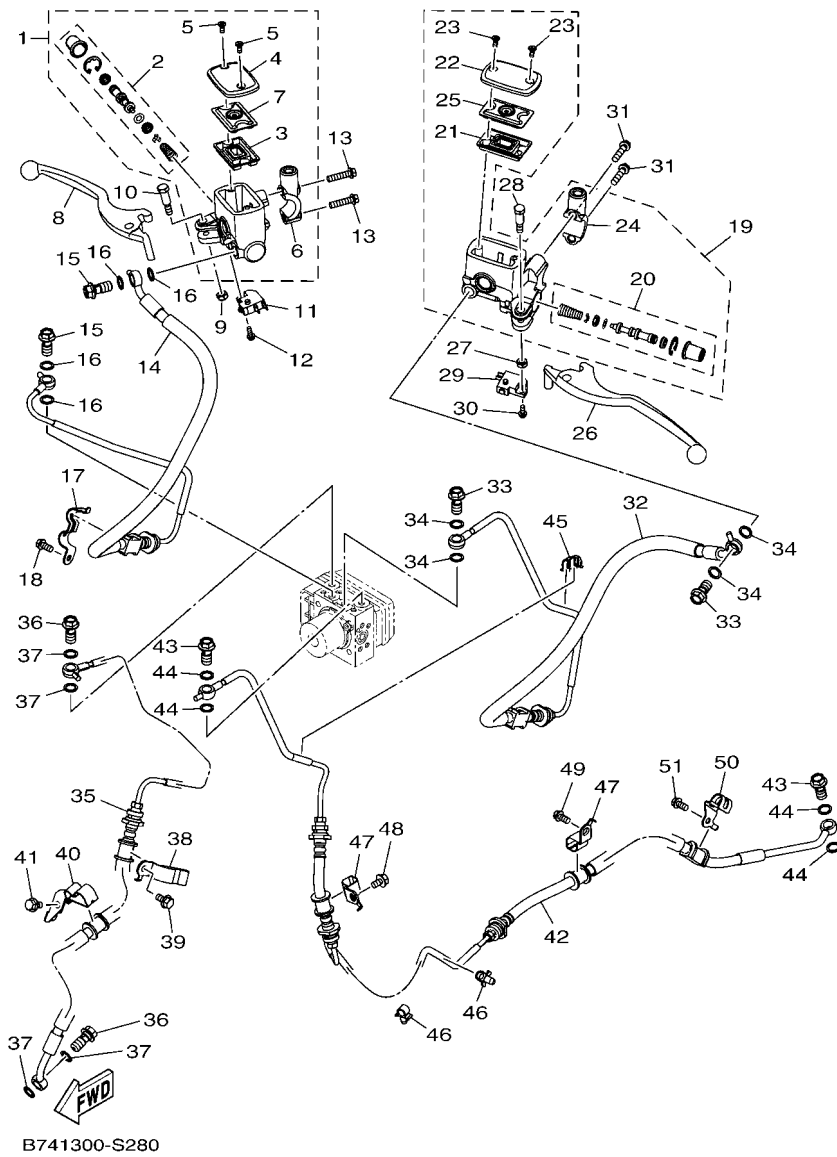

FIG. 27 STEERING HANDLE & CABLE

REF. NO.	PART NO.	DESCRIPTION	B74C				REMARKS
1	B74-F6110-00	HANDLE COMP.	1				
2	2DP-F6241-00	GRIP	1				
3	2DP-F6240-00	GRIP ASSY	1				
4	1PA-F6246-10	END, GRIP	2				
5	91317-06030	BOLT,HEX.SOCKET HEAD	2				
6	B74-F6301-00	THROTTLE CABLE ASSY	1				
7	92012-06010	BOLT, BUTTON HEAD	2				
8	92017-05016	BOLT, BUTTON HEAD	1				
9	B74-F637G-00	HOLDER, WIRE	1				
10	95022-06012	BOLT, FLANGE	1				
11	B74-F6280-00	REAR VIEW MIRROR ASSY (LEFT)	1				
12	B74-F6290-00	REAR VIEW MIRROR ASSY (RIGHT)	1				
13	B74-F6144-00	COVER, HANDLEBAR LOWER 1	1				
14	97702-50016	SCREW, TAPPING	4				
15	90183-06818	NUT, SPRING	1				
16	90183-05807	NUT, SPRING	1				
17	B74-F6213-00	COVER, UPPER	1				
18	90167-05076	SCREW, TAPPING	2				
19	90160-05808	SCREW, ROUND TAPPING	1				
20	90269-06816	RIVET	2				
21	B74-F6145-00-P0	COVER, HANDLE UPPER 2	1				MBL2 FOR MBL2,MS1
22	90149-06104	SCREW	1				
23	B74-F836B-00	TUNING FORK MARK	1				

FIG. 28 FRONT MASTER CYLINDER



B741300-S280

REF. NO.	PART NO.	DESCRIPTION	B74C				REMARKS
1	B74-F5870-10	MASTER CYLINDER SUB ASSY	1				
2	B74-F5807-00	.CYLINDER KIT, MASTER	1				
3	5RB-25854-00	.DIAPHRAGM, RESERVOIR	1				
4	1WD-F5852-00	.CAP, RESERVOIR	1				
5	36Y-2589H-00	.SCREW	2				
6	B74-F5867-00	.BRACKET, MASTER CYLINDER	1				
7	3C1-F5855-00	.BUSH,DIAPHRAGM	1				
8	B74-H3922-00	LEVER 2	1				
9	95602-06100	NUT, SELF-LOCKING	1				
10	90109-06577	BOLT	1				
11	2DP-H3980-00	FRONT STOP SWITCH ASSY	1				
12	97602-04212	SCREW, PAN HEAD WITH WASHER	1				
13	95027-06025	BOLT, FLANGE	2				
14	B74-F5872-00	HOSE, BRAKE 1	1				
15	90401-10812	BOLT, UNION	2				
16	90201-10118	WASHER, PLATE	4				
17	B74-F5886-00	HOLDER, BRAKE HOSE	1				
18	95022-06012	BOLT, FLANGE	1				
19	B74-F5870-00	MASTER CYLINDER SUB ASSY	1				
20	B74-F5807-00	.CYLINDER KIT, MASTER	1				
21	5RB-25854-00	.DIAPHRAGM, RESERVOIR	1				
22	1WD-F5852-00	.CAP, RESERVOIR	1				
23	36Y-2589H-00	.SCREW	2				
24	B74-F5867-00	.BRACKET, MASTER CYLINDER	1				
25	3C1-F5855-00	.BUSH,DIAPHRAGM	1				
26	B74-H3912-00	LEVER 1	1				
27	95602-06100	NUT, SELF-LOCKING	1				

FIG. 28 FRONT MASTER CYLINDER

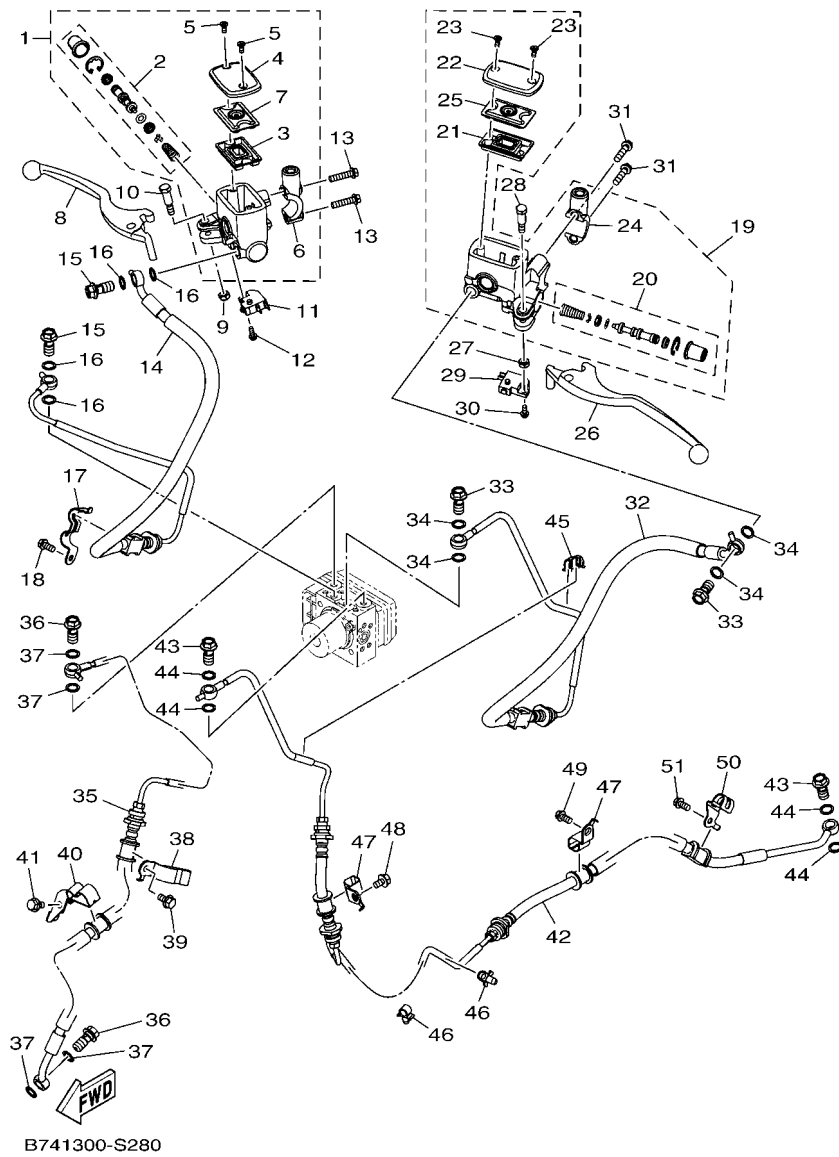

REF. NO.	PART NO.	DESCRIPTION	B74C				REMARKS
28	90109-06577	BOLT	1				
29	2DP-H2530-00	STOP SWITCH ASSY	1				
30	97602-04212	SCREW, PAN HEAD WITH WASHER	1				
31	95027-06025	BOLT, FLANGE	2				
32	B74-F5873-00	HOSE, BRAKE 2	1				
33	90401-10812	BOLT, UNION	2				
34	90201-10118	WASHER, PLATE	4				
35	B74-F5874-00	HOSE, BRAKE	1				
36	90401-10812	BOLT, UNION	2				
37	90201-10118	WASHER, PLATE	4				
38	B74-F5875-00	HOLDER, BRAKE HOSE 1	1				
39	95807-06012	BOLT, FLANGE	1				
40	B74-F5887-00	HOLDER, BRAKE HOSE	1				
41	95807-06012	BOLT, FLANGE	1				
42	B74-F581J-00	HOSE, BRAKE 4	1				
43	90401-10812	BOLT, UNION	2				
44	90201-10118	WASHER, PLATE	4				
45	90464-06008	CLAMP	1				
46	90464-07805	CLAMP	2				
47	B74-F5876-00	HOLDER, BRAKE HOSE 2	2				
48	95807-06010	BOLT, FLANGE	1				
49	95802-06012	BOLT, FLANGE	1				
50	B74-F587A-00	HOLDER, BRAKE HOSE	1				
51	95802-06012	BOLT, FLANGE	1				

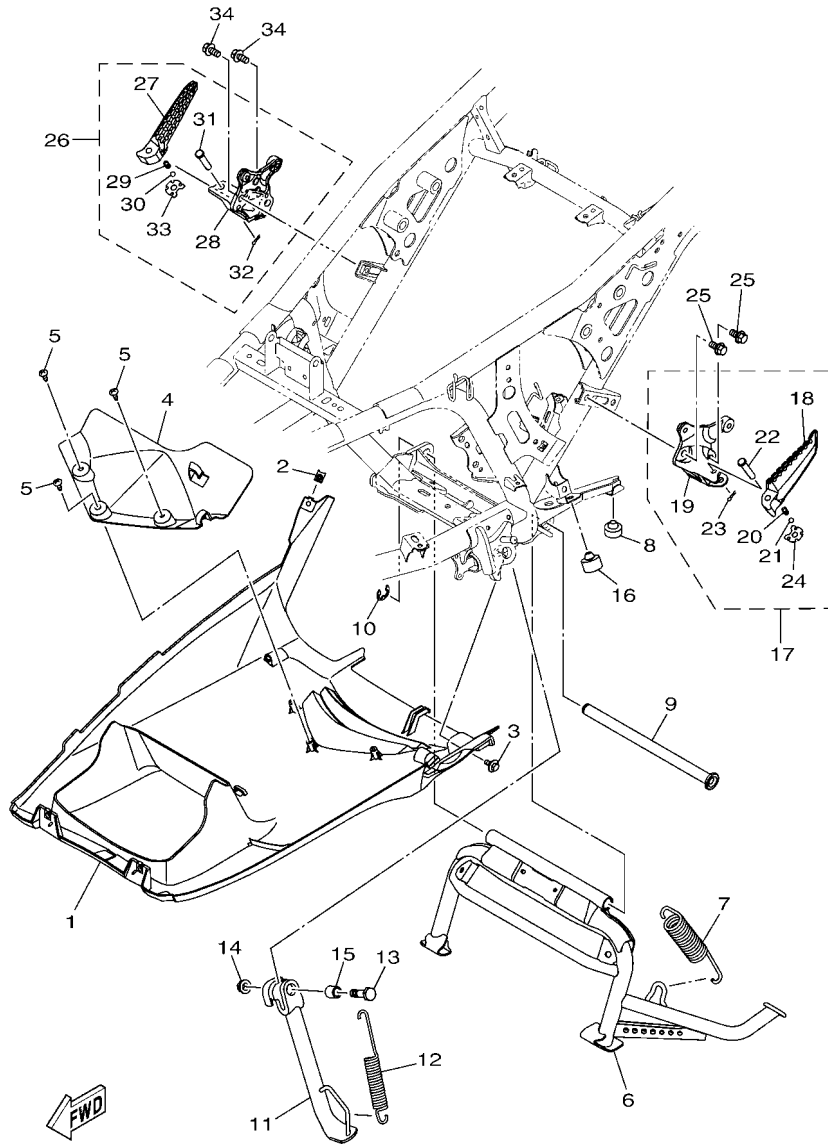

B741300-S290

FIG. 29 STAND & FOOTREST

REF. NO.	PART NO.	DESCRIPTION	B74C	REMARKS
1	B74-F8385-00	COVER, UNDER	1	
2	90183-05807	NUT, SPRING	1	
3	90109-06887	BOLT	1	
4	B74-F838N-00	DUCT 1	1	
5	97702-50016	SCREW, TAPPING	3	
6	B74-F7111-00	STAND, MAIN	1	
7	90506-40805	SPRING, TENSION	1	
8	45P-F7114-00	STOPPER, MAIN STAND	1	
9	B74-F7261-00	SHAFT	1	
10	93430-12809	CIRCLIP	1	
11	B74-F7311-00	STAND, SIDE	1	
12	90506-32813	SPRING, TENSION	1	
13	90101-10830	BOLT	1	
14	95602-10200	NUT, S/L FLANGE	1	
15	90387-10849	COLLAR	1	
16	4YY-F7114-00	STOPPER, MAIN STAND	1	
17	B74-F7430-00	REAR FOOTREST ASSY 1	1	
18	2DP-F7431-01	.FOOTREST, REAR 1	1	
19	B74-F741L-00	.BRACKET 4	1	
20	90501-12743	.SPRING, COMPRESSION	1	
21	93501-04830	.BALL	1	
22	91702-08038	.PIN, CLEVIS	1	
23	91402-25015	.PIN, COTTER	1	
24	B74-F7437-00	.WASHER, SPECIAL	1	
25	95812-08016	BOLT, FLANGE	2	
26	B74-F7440-00	REAR FOOTREST ASSY 2	1	
27	2DP-F7441-01	.FOOTREST, REAR 2	1	

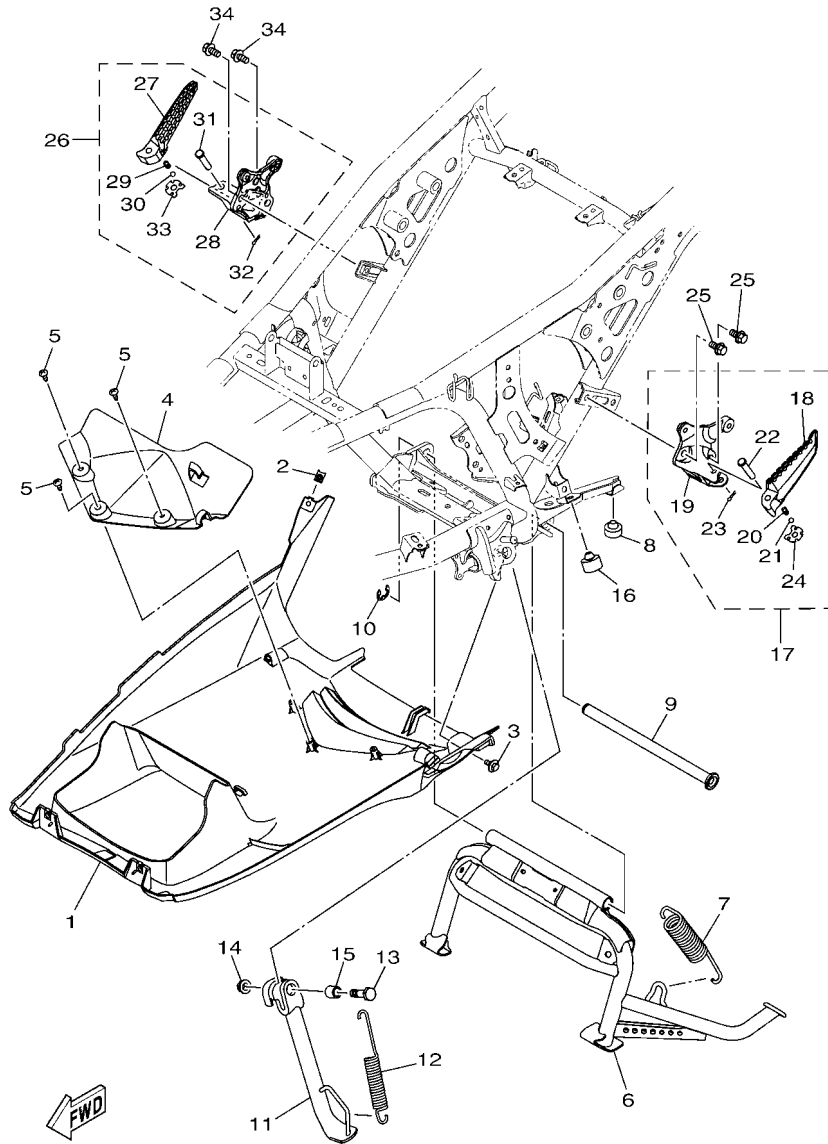

B741300-S290

FIG. 29 STAND & FOOTREST

REF. NO.	PART NO.	DESCRIPTION	B74C	REMARKS
28	B74-F742L-00	.BRACKET 5	1	
29	90501-12743	.SPRING, COMPRESSION	1	
30	93501-04830	.BALL	1	
31	91702-08038	.PIN, CLEVIS	1	
32	91402-25015	.PIN, COTTER	1	
33	B74-F7437-00	.WASHER, SPECIAL	1	
34	95812-08016	BOLT, FLANGE	2	

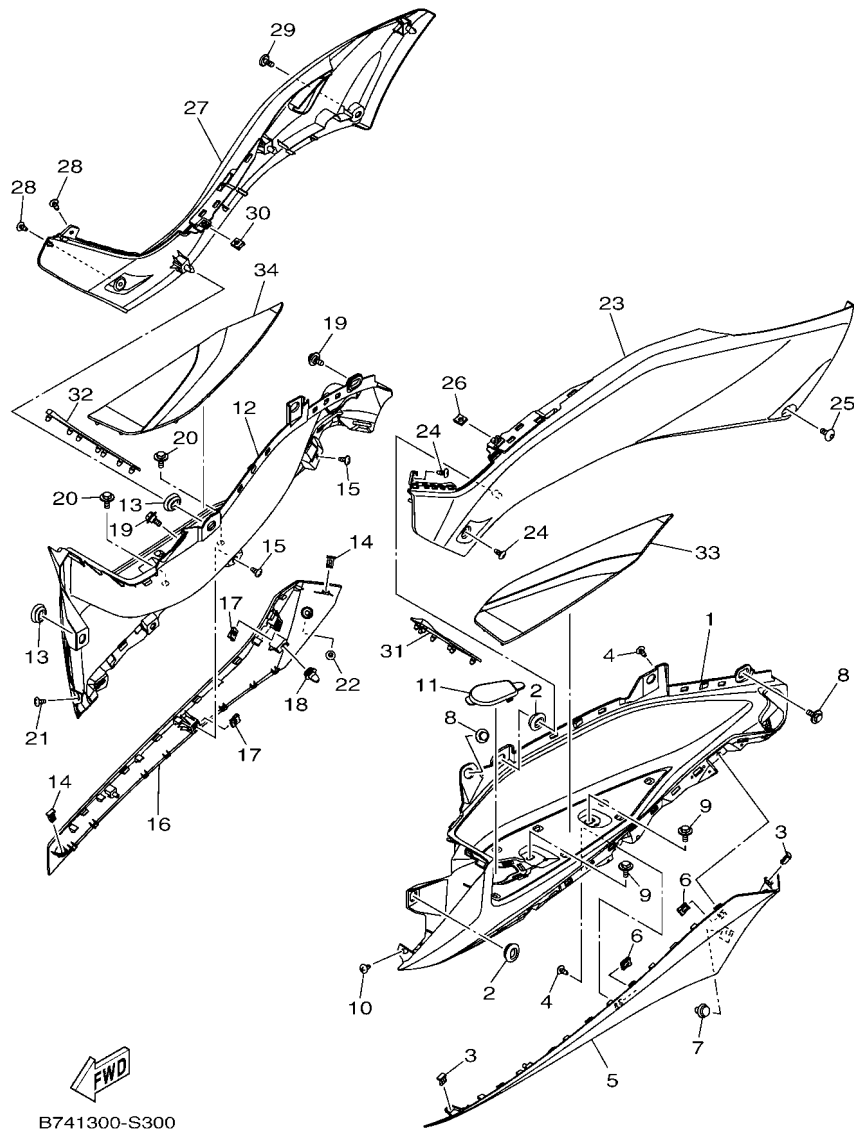
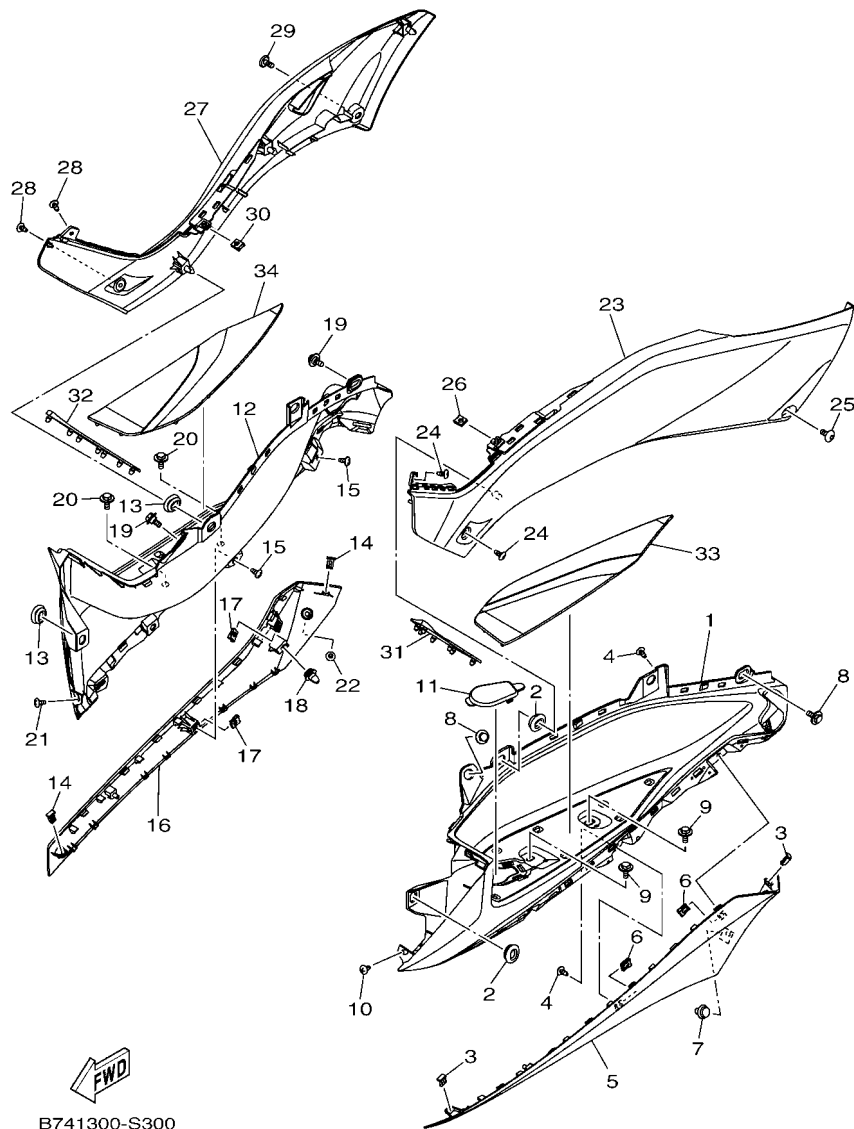

FIG. 30 STAND & FOOTREST 2

REF. NO.	PART NO.	DESCRIPTION	B74C	REMARKS
1	B74-F7481-00	BOARD, FOOTREST	1	
2	90480-01559	GROMMET	2	
3	90464-04004	CLAMP	2	
4	97702-50012	SCREW, TAPPING	2	
5	B74-F171L-00-P4	MOLE, SIDE COVER 1	1	UR FOR MBL2
	B74-F171L-00-P5	MOLE, SIDE COVER 1	1	UR FOR MS1
6	90183-05807	NUT, SPRING	2	
7	90269-09005	RIVET	1	
8	90109-06887	BOLT	2	
9	90119-06051	BOLT, WITH WASHER	2	
10	97702-50012	SCREW, TAPPING	1	
11	2DP-F172W-00	COVER	1	
12	B74-F7488-00	BOARD, FOOTREST 2	1	
13	90480-01559	GROMMET	2	
14	90464-04004	CLAMP	2	
15	97702-50012	SCREW, TAPPING	2	
16	B74-F171M-00-P4	MOLE, SIDE COVER 2	1	UR FOR MBL2
	B74-F171M-00-P5	MOLE, SIDE COVER 2	1	UR FOR MS1
17	90183-05807	NUT, SPRING	2	
18	90269-09005	RIVET	1	
19	90109-06887	BOLT	2	
20	90119-06051	BOLT, WITH WASHER	2	
21	97702-50012	SCREW, TAPPING	1	
22	90160-05808	SCREW, ROUND TAPPING	1	
23	B74-F1711-00-P2	COVER, SIDE 1	1	UR SMX FOR MBL2
	B74-F1711-00-P0	COVER, SIDE 1	1	UR MBL2 FOR MS1
24	90160-05808	SCREW, ROUND TAPPING	2	

FIG. 30 STAND & FOOTREST 2



B741300-S300

REF. NO.	PART NO.	DESCRIPTION	B74C				REMARKS
25	90111-06839	BOLT,HEX. SOCKET BUTTON	1				
26	90183-05807	NUT, SPRING	1				
27	B74-F1721-00-P2	COVER, SIDE 2	1				UR SMX FOR MBL2
	B74-F1721-00-P0	COVER, SIDE 2	1				UR MBL2 FOR MS1
28	90160-05808	SCREW, ROUND TAPPING	2				
<hr/>							
29	90111-06839	BOLT,HEX. SOCKET BUTTON	1				
30	90183-05807	NUT, SPRING	1				
31	B74-F7483-00	MAT 1	1				
32	B74-F7484-00	MAT 2	1				
33	B74-F7493-00	MAT 3	1				
34	B74-F7494-00	MAT 4	1				
<hr/>							
<hr/>							
<hr/>							
<hr/>							
<hr/>							
<hr/>							
<hr/>							
<hr/>							
<hr/>							
<hr/>							

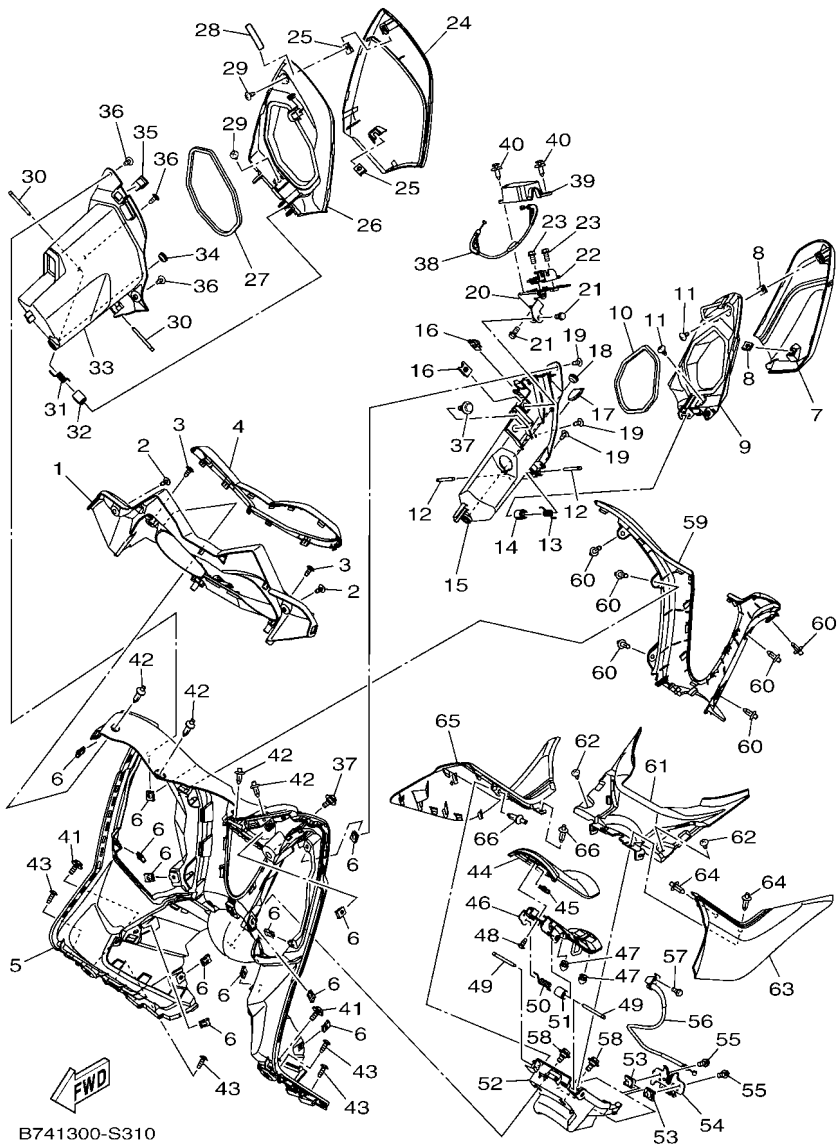

B741300-S310

FIG. 31 LEG SHIELD

REF. NO.	PART NO.	DESCRIPTION	B74C	REMARKS
1	B74-F836K-00	PANEL, INNER 1	1	
2	90160-05808	SCREW, ROUND TAPPING	2	
3	97702-50012	SCREW, TAPPING	2	
4	B74-F8346-00-P0	MOLE 2	1	MBL2 FOR MBL2,MS1
5	B74-F8311-00	LEG SHIELD 1	1	
6	90183-05807	NUT, SPRING	12	
7	B74-F836L-00	PANEL, INNER 2	1	
8	90183-05807	NUT, SPRING	2	
9	B74-F839L-00	LID 2	1	
10	90520-06808	DAMPER, PLATE	1	
11	97707-50012	SCREW, TRUSS HEAD TAPPING	2	
12	B74-F818A-00	PIN	2	
13	90508-13800	SPRING, TORSION	1	
14	B74-F834F-00	DAMPER	1	
15	B74-F838L-00	BOX 2	1	
16	90183-06818	NUT, SPRING	2	
17	B74-F8349-00	CAP	1	
18	4US-F6199-00	PLUG, BLIND	1	
19	97707-50012	SCREW, TRUSS HEAD TAPPING	3	
20	B74-F8357-00	STAY 2	1	
21	95022-06012	BOLT, FLANGE	2	
22	1DY-F4780-00	SEAT LOCK ASSY	1	
23	95022-06012	BOLT, FLANGE	2	
24	B74-F836M-00	PANEL, INNER 3	1	
25	90183-05807	NUT, SPRING	2	
26	B74-F839V-00	LID 3	1	
27	90520-06808	DAMPER, PLATE	1	

FIG. 31 LEG SHIELD

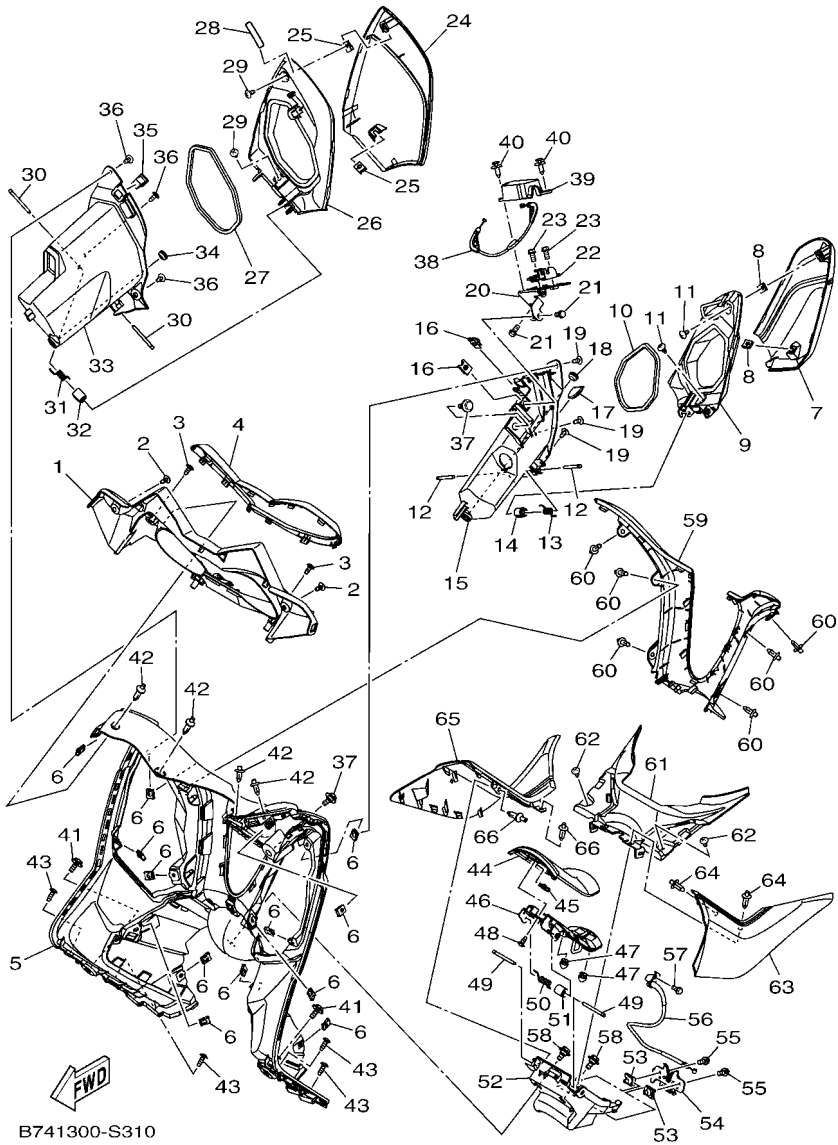

B741300-S310

REF. NO.	PART NO.	DESCRIPTION	B74C	REMARKS
28	B74-F8336-00	PLATE	1	
29	97707-50012	SCREW, TRUSS HEAD TAPPING	2	
30	B74-F818A-00	PIN	2	
31	90508-13801	SPRING, TORSION	1	
32	B74-F834F-00	DAMPER	1	
33	B74-F838V-00	BOX 3	1	
34	4US-F6199-00	PLUG, BLIND	1	
35	90464-13801	CLAMP	1	
36	97707-50012	SCREW, TRUSS HEAD TAPPING	3	
37	90109-06887	BOLT	2	
38	B74-F835X-00	WIRE	1	
39	B74-F8365-00	COVER	1	
40	90269-06812	RIVET	2	
41	90119-06051	BOLT, WITH WASHER	2	
42	90269-06816	RIVET	4	
43	97702-50016	SCREW, TAPPING	4	
44	B74-F74A8-00-P0	LID, FUEL	1	MBL2 FOR MBL2,MS1
45	90183-05807	NUT, SPRING	1	
46	B74-F839W-00	LID 4	1	
47	4G0-21639-00	DAMPER 2	2	
48	97702-50012	SCREW, TAPPING	1	
49	B74-F818A-00	PIN	2	
50	90508-14803	SPRING, TORSION	1	
51	B74-F834F-00	DAMPER	1	
52	B74-F838W-00	BOX 4	1	
53	90183-06818	NUT, SPRING	2	
54	1DY-F4780-00	SEAT LOCK ASSY	1	

FIG. 31 LEG SHIELD

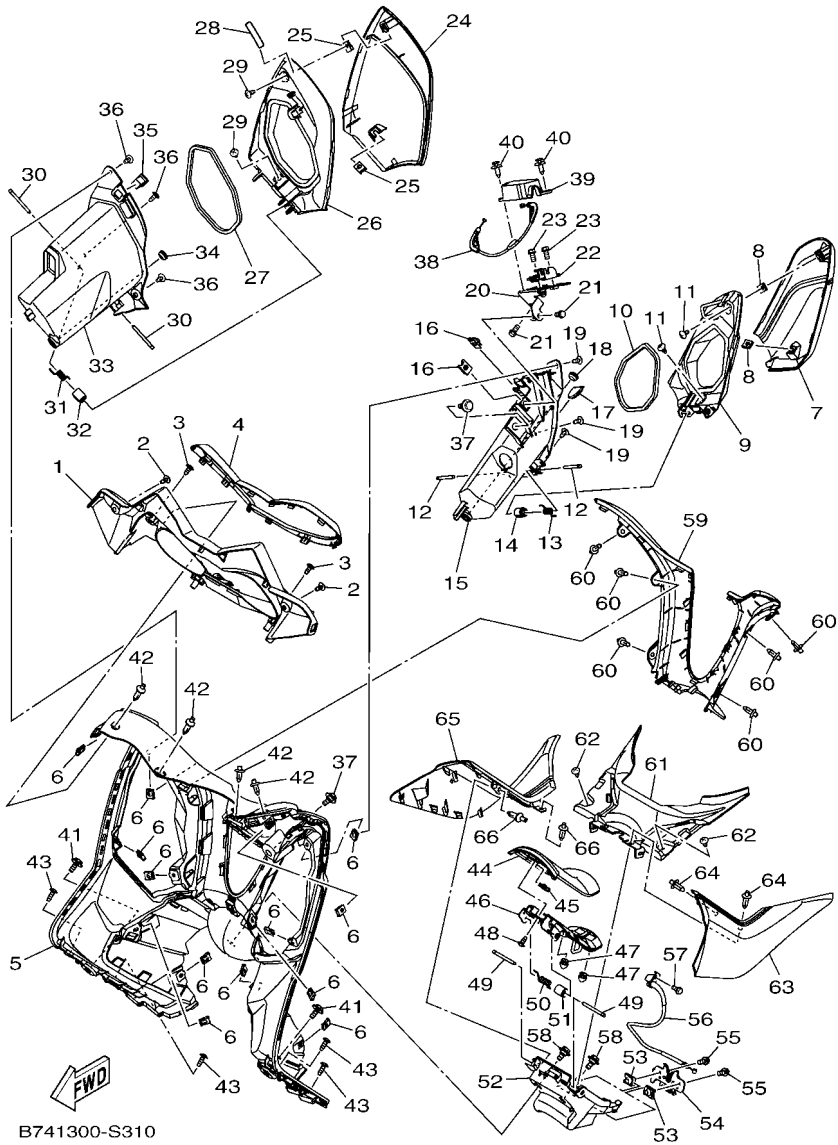

REF. NO.	PART NO.	DESCRIPTION	B74C				REMARKS
55	95022-06012	BOLT, FLANGE	2				
56	B74-F4494-00	WIRE, PULL	1				
57	97527-05512	BOLT, WITH WASHER	1				
58	90109-06220	BOLT	2				
59	B74-F8312-00-P0	LEG SHIELD 2	1				MBL2 FOR MBL2,MS1
<hr/>							
60	90269-06816	RIVET	6				
61	B74-F842M-00	COVER 1	1				
62	97702-50012	SCREW, TAPPING	2				
63	B74-F837L-00	PANEL, CONSOLE 1	1				
64	90269-06816	RIVET	2				
<hr/>							
65	B74-F837M-00	PANEL, CONSOLE 2	1				
66	90269-06816	RIVET	2				
<hr/>							
<hr/>							
<hr/>							
<hr/>							

FIG. 32 WINDSHIELD

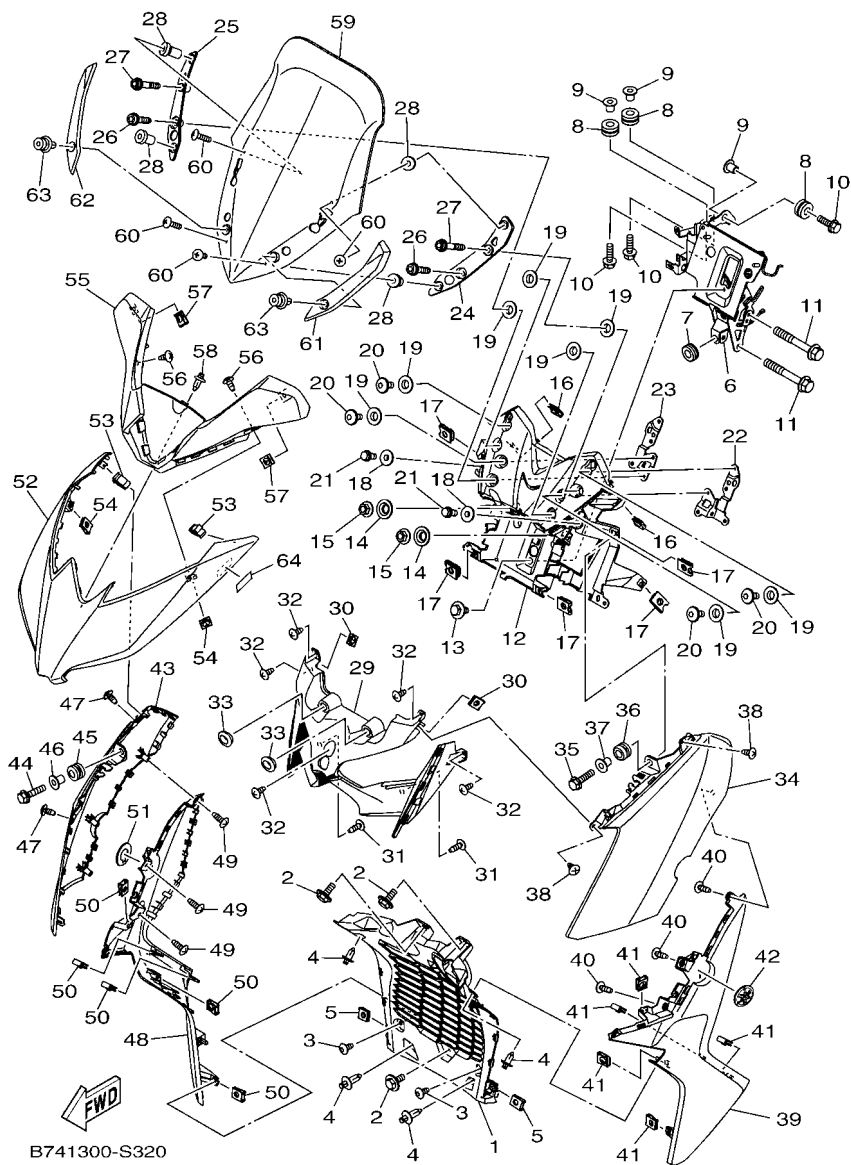

B741300-S320

REF. NO.	PART NO.	DESCRIPTION	B74C	REMARKS
1	B74-F837N-00	GRILL, AIR INTAKE 1	1	
2	90119-06051	BOLT, WITH WASHER	3	
3	90160-05808	SCREW, ROUND TAPPING	2	
4	90269-06816	RIVET	4	
5	90183-05807	NUT, SPRING	2	
6	B74-F8321-00	STAY 1	1	
7	90480-10289	GROMMET	1	
8	90480-14229	GROMMET	3	
9	90387-068N8	COLLAR	3	
10	95802-06020	BOLT, FLANGE	3	
11	95812-08055	BOLT, FLANGE	2	
12	B74-H212B-00	BOX, BATTERY 1	1	
13	90109-06887	BOLT	1	
14	90387-09805	COLLAR	2	
15	90179-06841	NUT	2	
16	90183-05807	NUT, SPRING	2	
17	90183-06818	NUT, SPRING	5	
18	90387-06048	COLLAR	2	
19	90387-09808	COLLAR	8	
20	90111-06839	BOLT,HEX. SOCKET BUTTON	4	
21	95022-06012	BOLT, FLANGE	2	
22	B74-F8306-00	PLATE, WINDSHIELD	1	
23	B74-F835P-00	PLATE, WINDSHIELD 2	1	
24	B74-F8322-00	STAY 2	1	
25	B74-F8332-00	STAY, LEG SHIELD	1	
26	90110-06380	BOLT, HEXAGON SOCKET HEAD	2	
27	90109-06009	BOLT	2	

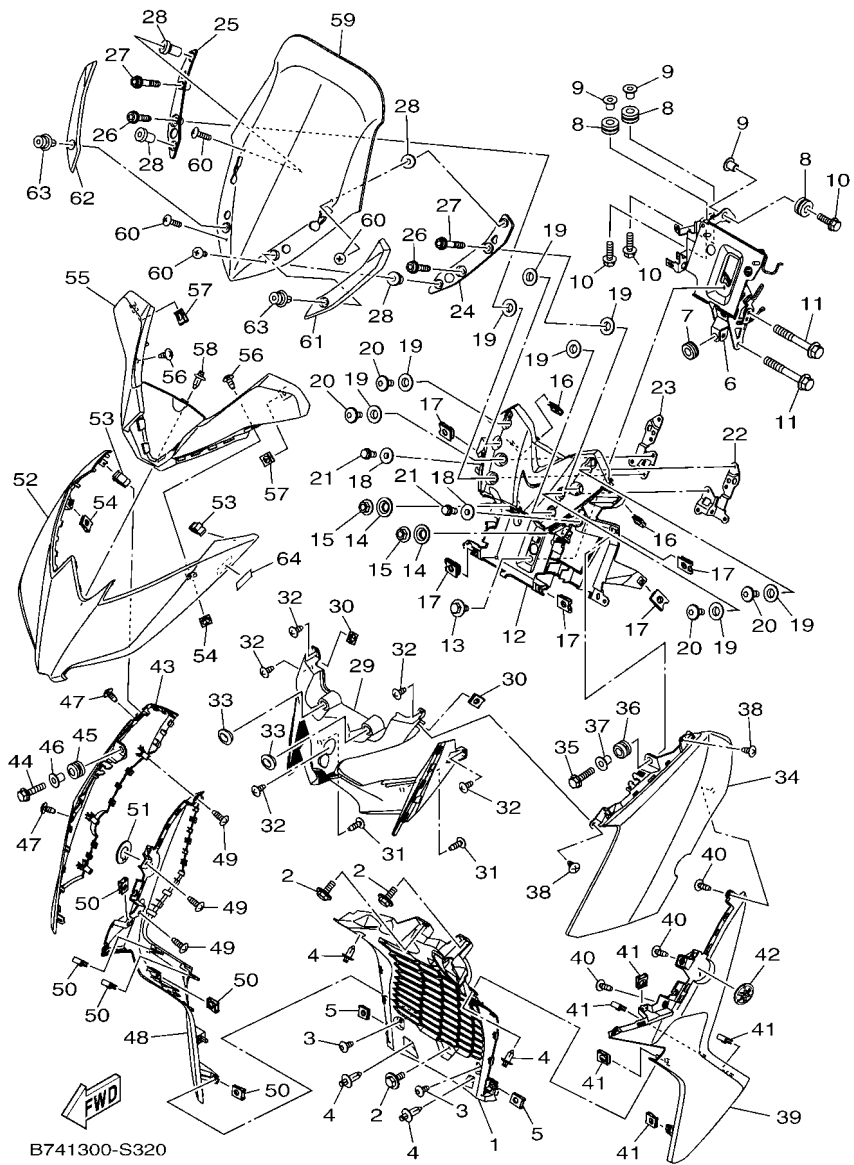

B741300-S320

FIG. 32 WINDSHIELD

REF. NO.	PART NO.	DESCRIPTION	B74C	REMARKS
28	90179-05003	NUT	4	
29	B74-F286F-00	COVER, FRONT 2	1	
30	90183-05807	NUT, SPRING	2	
31	97702-50016	SCREW, TAPPING	2	
32	97702-50012	SCREW, TAPPING	5	
33	90480-01558	GROMMET	2	
34	B74-F8351-00-P4	BODY, COWLING	1	UR FOR MBL2
	B74-F8351-00-P5	BODY, COWLING	1	UR FOR MS1
35	95802-06025	BOLT, FLANGE	1	
36	90480-14023	GROMMET	1	
37	90387-06158	COLLAR	1	
38	97702-50012	SCREW, TAPPING	2	
39	B74-F835J-00-P1	BODY, FRONT UNDER 1	1	UR SMX FOR MBL2
	B74-F835J-00-P0	BODY, FRONT UNDER 1	1	UR MBL2 FOR MS1
40	97702-50016	SCREW, TAPPING	3	
41	90183-05807	NUT, SPRING	5	
42	B74-F414B-00	EMBLEM	1	
43	B74-F8377-00-P4	BODY, COWLING 2	1	UR FOR MBL2
	B74-F8377-00-P5	BODY, COWLING 2	1	UR FOR MS1
44	95802-06025	BOLT, FLANGE	1	
45	90480-14023	GROMMET	1	
46	90387-06158	COLLAR	1	
47	97702-50012	SCREW, TAPPING	2	
48	B74-F835K-00-P0	BODY, FRONT UNDER 2	1	UR MBL2 FOR MS1
	B74-F835K-00-P1	BODY, FRONT UNDER 2	1	UR SMX FOR MBL2
49	97702-50016	SCREW, TAPPING	3	
50	90183-05807	NUT, SPRING	5	

FIG. 32 WINDSHIELD

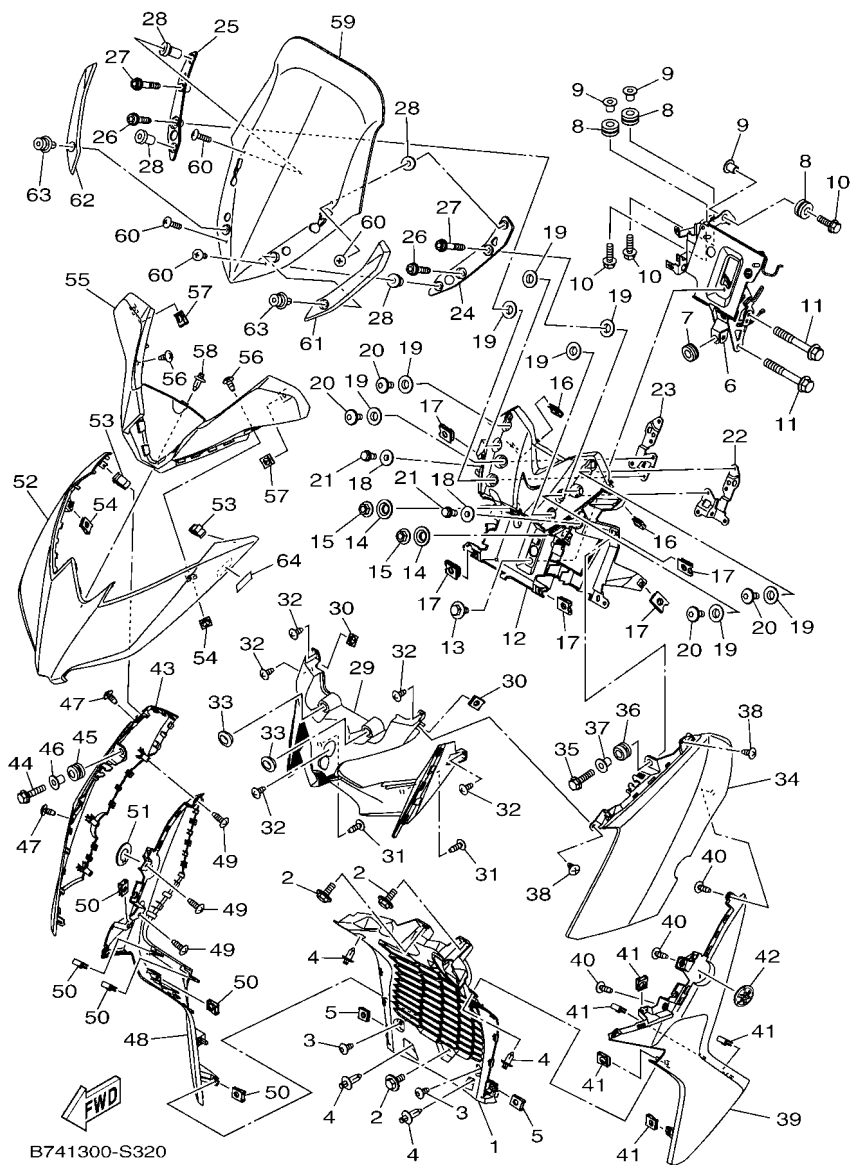

B741300-S320

REF. NO.	PART NO.	DESCRIPTION	B74C	REMARKS
51	B74-F414B-00	EMBLEM	1	
52	B74-F2865-00-P0	COVER, FRONT	1	MBL2 FOR MBL2,MS1
53	90464-07018	CLAMP	2	
54	90183-05807	NUT, SPRING	2	
55	B74-H2129-00	COVER, BATTERY	1	
56	97702-50012	SCREW, TAPPING	2	
57	90183-05807	NUT, SPRING	2	
58	90269-06816	RIVET	1	
59	B74-F837U-00	SCREEN	1	
60	90150-05024	SCREW, ROUND HEAD	4	
61	B74-F842A-00	COVER 5	1	
62	B74-F843C-00	COVER 6	1	
63	90269-08007	RIVET	2	
64	2PH-F1737-00	EMBLEM	1	

FIG. 33 GENERATOR

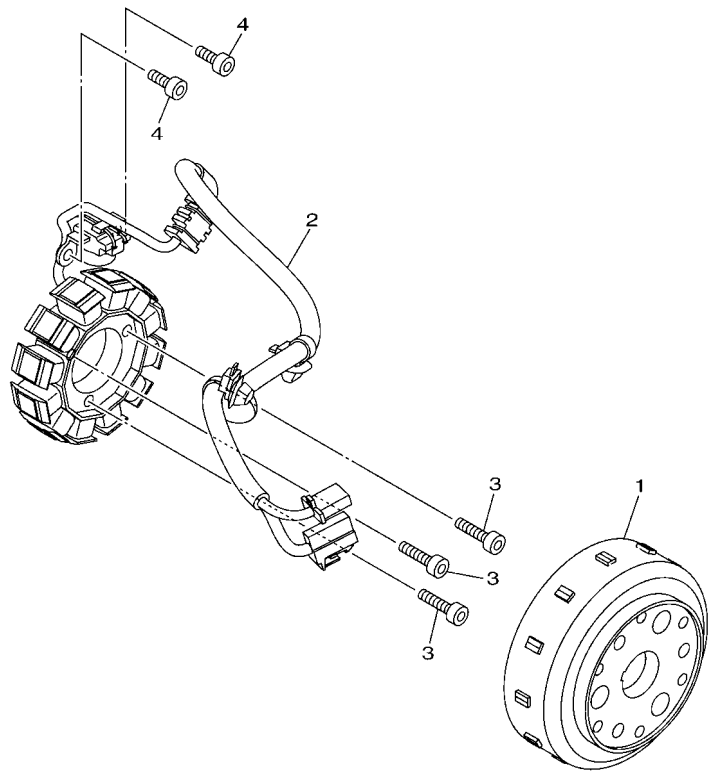

 B741300-S330

REF. NO.	PART NO.	DESCRIPTION	B74C				REMARKS
1	B74-H1450-00	ROTOR ASSY	1				
2	B74-H1410-00	STATOR ASSY	1				
3	90110-06178	BOLT, HEXAGON SOCKET HEAD	3				
4	90110-06161	BOLT, HEXAGON SOCKET HEAD	2				

FIG. 34 STARTING MOTOR

REF. NO.	PART NO.	DESCRIPTION	B74C				REMARKS
1	B74-H1890-00	MOTOR ASSY	1				
2	B74-H1801-00	.BRUSH SET	1				
3	1WD-H1861-00	.GASKET	2				
4	1WD-H1828-00	.BOLT 2	2				
5	4FP-H182L-00	.O-RING 1	1				
6	B74-H1948-00	BRACKET	1				
7	90110-06172	BOLT, HEXAGON SOCKET HEAD	2				

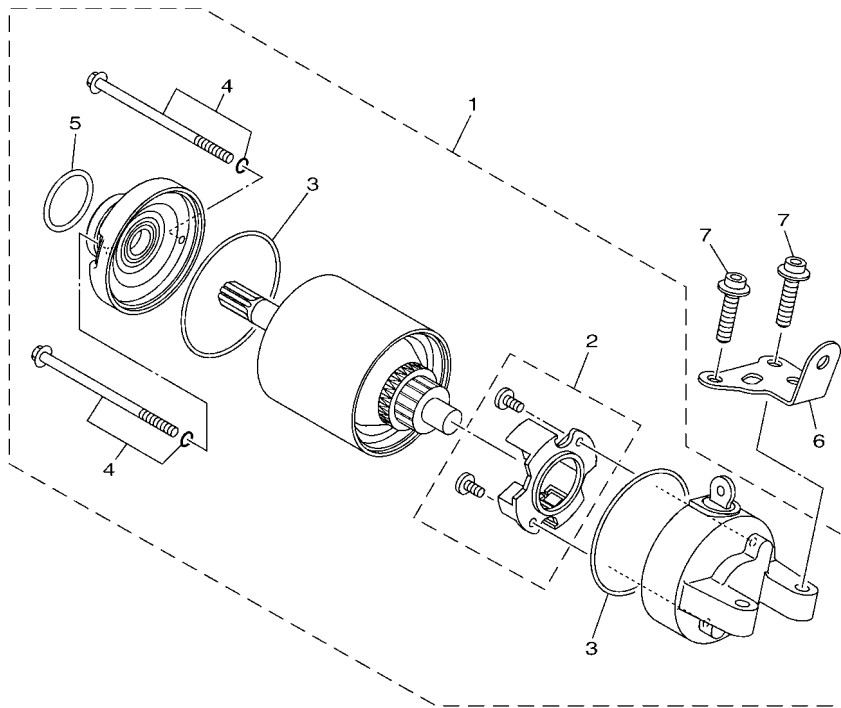

B741300-S340

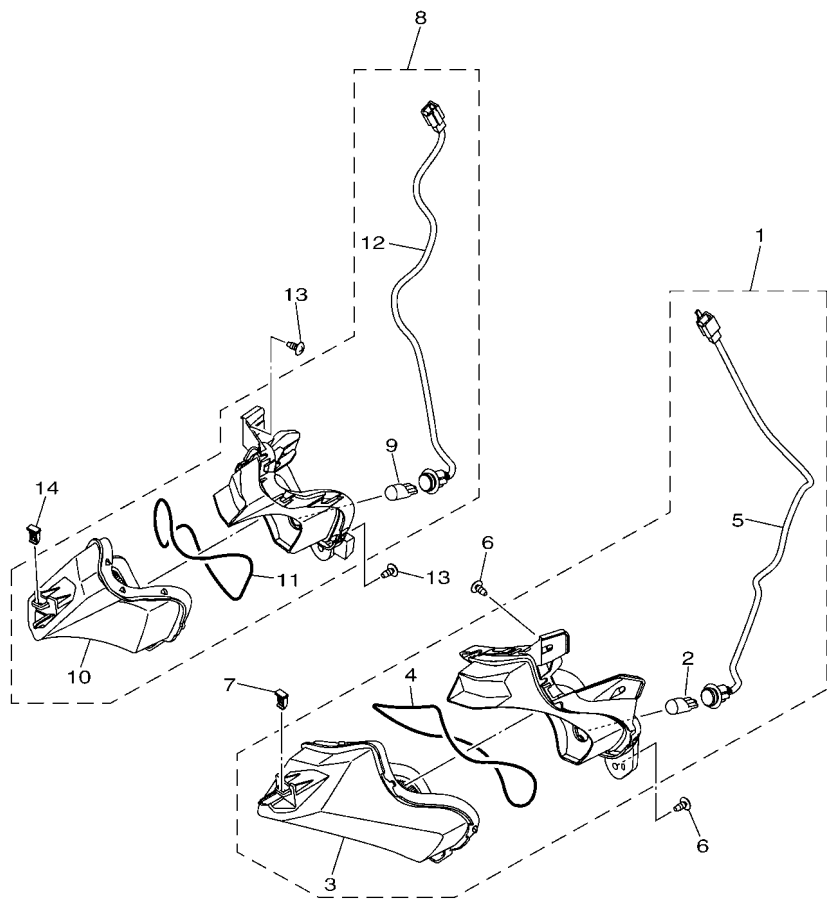
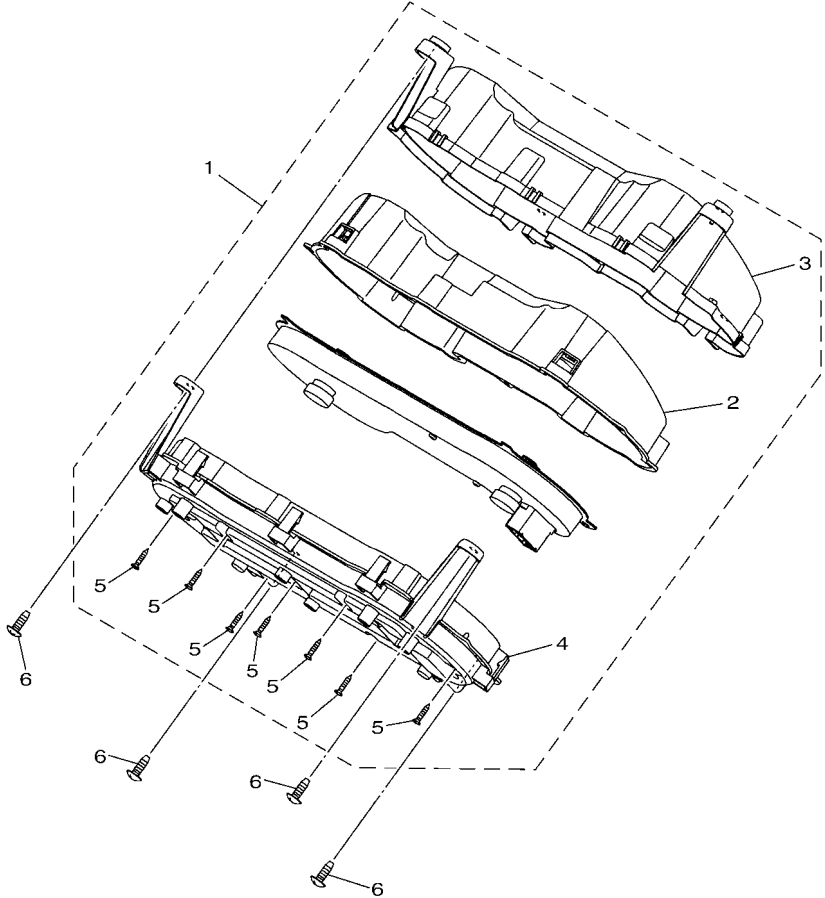

FIG. 35 FLASHER LIGHT

REF. NO.	PART NO.	DESCRIPTION	B74C				REMARKS
1	B74-H3310-00	FRONT FLASHER LIGHT ASSY 1	1				
2	2CB-H3311-00	.BULB, FLASHER (12V-10W)	1				
3	B74-H3312-00	.LENS, FLASHER	1				
4	B74-H4723-00	.GASKET, TAIL LENS	1				
5	B74-H4140-00	.SOCKET CORD ASSY	1				
6	97702-50012	SCREW, TAPPING	2				
7	90464-04004	CLAMP	1				
8	B74-H3320-00	FRONT FLASHER LIGHT ASSY 2	1				
9	2CB-H3311-00	.BULB, FLASHER (12V-10W)	1				
10	B74-H3322-00	.LENS, FLASHER 2	1				
11	B74-H4723-00	.GASKET, TAIL LENS	1				
12	B74-H4150-00	.SOCKET CORD ASSY 2	1				
13	97702-50012	SCREW, TAPPING	2				
14	90464-04004	CLAMP	1				

B741300-S350

FIG. 36 METER



B741300-S360

REF. NO.	PART NO.	DESCRIPTION	B74C					REMARKS
1	B74-H3500-00	METER ASSY	1					
2	B74-H353L-00	.REFLECTOR	1					
3	B74-H3511-00	.LENS, SPEEDOMETER	1					
4	B74-H3572-00	.CASE, SPEEDOMETER LOWER	1					
5	97702-30016	.SCREW, TAPPING	7					
6	97702-50016	SCREW, TAPPING	4					

FIG. 37 HEADLIGHT

REF. NO.	PART NO.	DESCRIPTION	B74C						REMARKS
1	B74-H4300-00	HEADLIGHT ASSY	1						
2	95802-06020	BOLT, FLANGE	2						
3	90480-10289	GROMMET	2						
4	90387-06899	COLLAR	2						
5	90183-05807	NUT, SPRING	4						

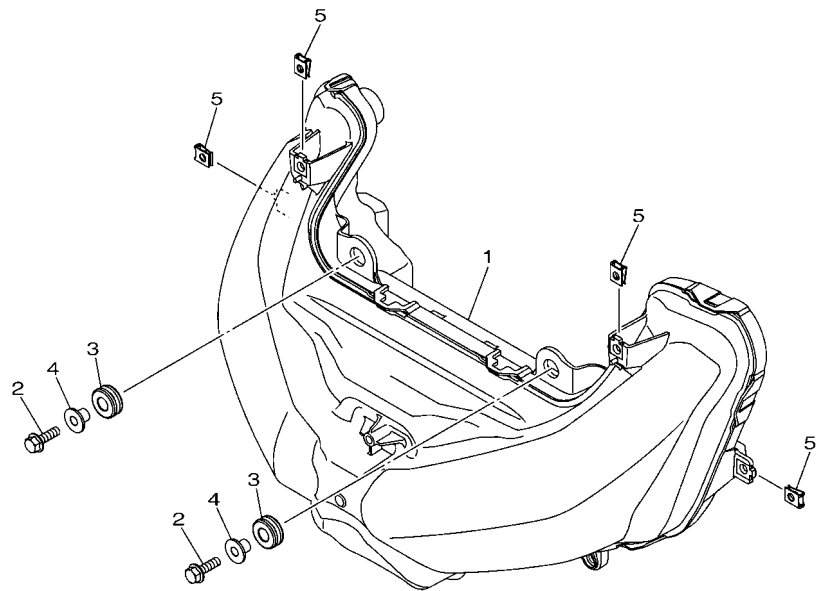

B741300-S370

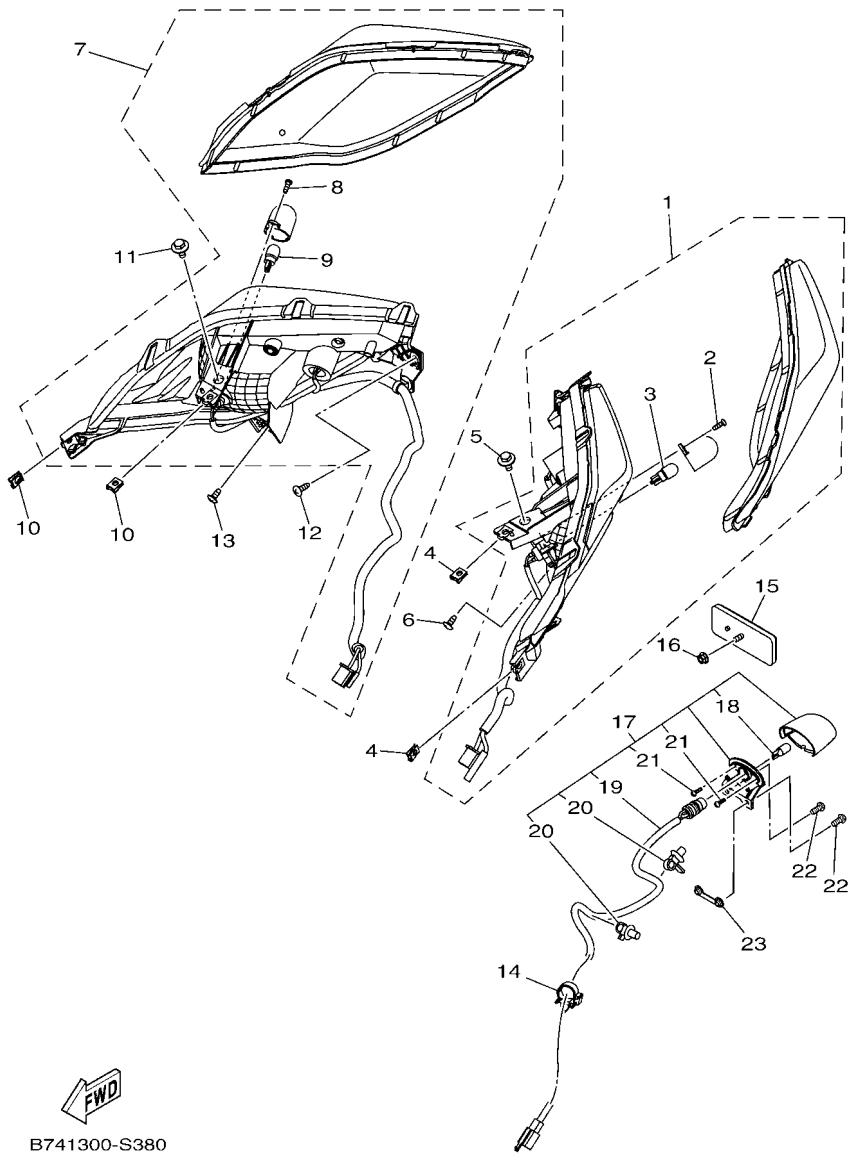

B741300-S380

FIG. 38 TAILLIGHT

REF. NO.	PART NO.	DESCRIPTION	B74C				REMARKS
1	B74-H4710-00	TAILLIGHT UNIT ASSY	1				
2	97702-40612	.SCREW, TAPPING	1				
3	1YT-83311-00	.BULB(12V-10W)	1				
4	90183-05807	NUT, SPRING	2				
5	90109-06887	BOLT	1				
6	97702-50012	SCREW, TAPPING	1				
7	B74-H4730-00	TAILLIGHT UNIT ASSY	1				
8	97702-40612	.SCREW, TAPPING	1				
9	1YT-83311-00	.BULB(12V-10W)	1				
10	90183-05807	NUT, SPRING	2				
11	90109-06887	BOLT	1				
12	97702-50016	SCREW, TAPPING	1				
13	97702-50012	SCREW, TAPPING	1				
14	90464-16006	CLAMP	1				
15	3C1-H5130-00	REAR REFLECTOR ASSY	1				
16	95702-05500	NUT, FLANGE	1				
17	B74-H4740-00	LICENCE LIGHT ASSY	1				
18	1WD-H4744-00	.BULB (12V-5W)	1				
19	B74-H4547-00	.CORD, LICENCE LIGHT	1				
20	B74-H454J-00	.CLAMP, CORD	2				
21	1WD-H4726-00	.SCREW	2				
22	92017-05012	BOLT, BUTTON HEAD	2				
23	B74-H4748-00	NUT, SPECIAL	1				

FIG. 39 HANDLE SWITCH & LEVER

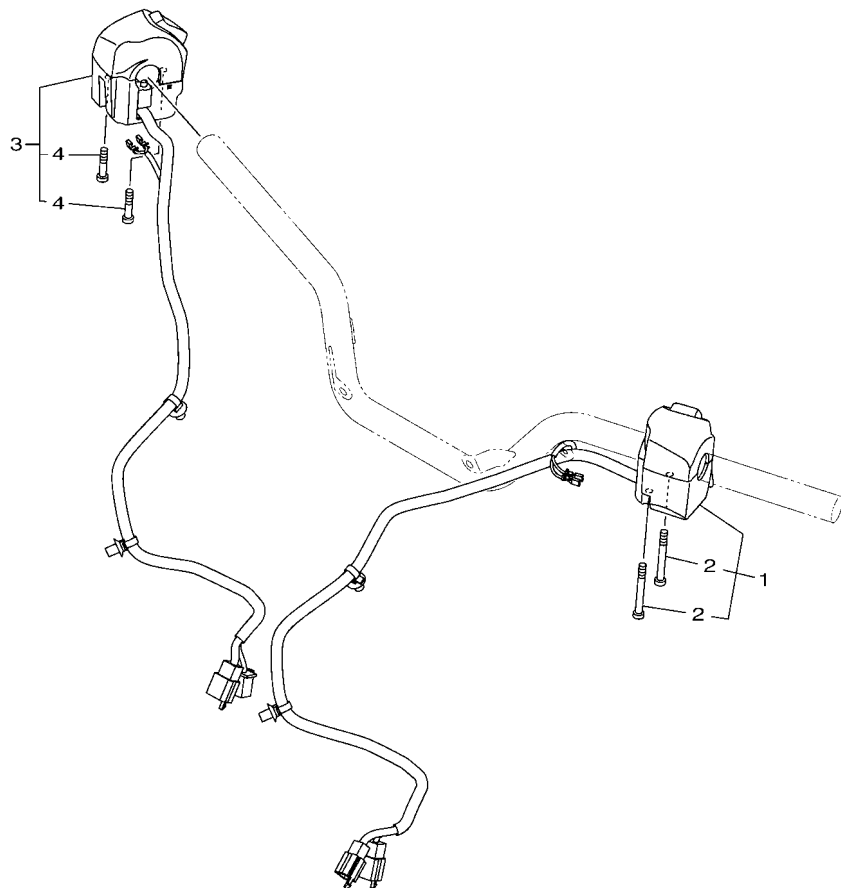

 B741300-S390

REF. NO.	PART NO.	DESCRIPTION	B74C				REMARKS
1	B74-H3963-00	SWITCH, HANDLE 3	1				
2	98507-05040	.SCREW, PAN HEAD	2				
3	B74-H3973-10	SWITCH, HANDLE 3	1				
4	98507-05025	.SCREW, PAN HEAD	2				

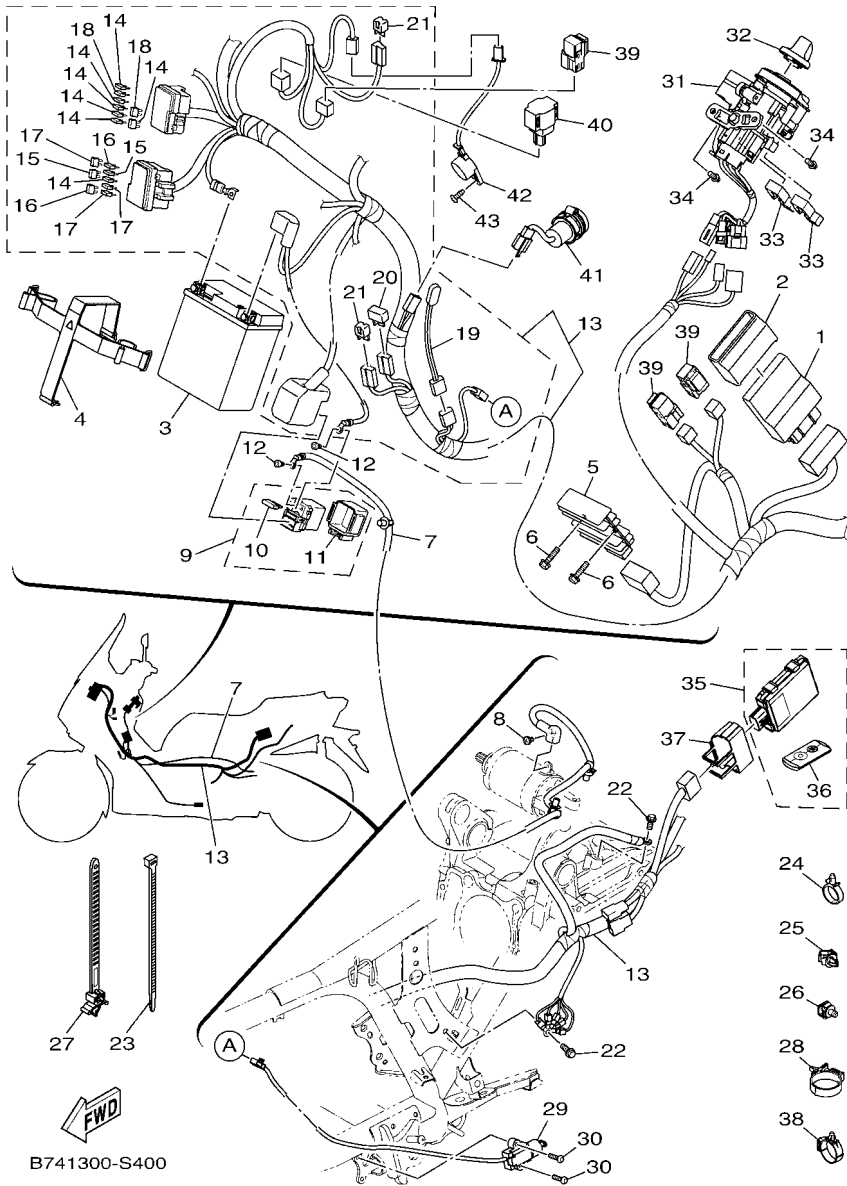

B741300-S400

FIG. 40 ELECTRICAL 1

REF. NO.	PART NO.	DESCRIPTION	B74C	REMARKS
1	B74-H591A-00	ENGINE CONTROL UNIT ASSY	1	
2	B74-H2591-00	BAND	1	
3	1WD-H2100-00	BATTERY ASSY (GS GTZ8V)	1	
4	B74-H2131-00	BAND, BATTERY	1	
5	2GS-H1960-01	RECTIFIER & REGULATOR ASSY	1	
6	95822-06025	BOLT, FLANGE	2	
7	B74-H1815-00	CORD, STARTER MOTOR	1	
8	98902-05008	SCREW, BIND	1	
9	B74-H1940-00	STARTER RELAY ASSY	1	
10	B74-H2151-A0	.FUSE (20A)	1	
11	1WD-H2155-00	.BAND	1	
12	91312-05008	BOLT, HEXAGON SOCKET HEAD	2	
13	B74-H2590-01	WIRE HARNESS ASSY	1	
14	B65-H2151-00	.FUSE (7.5A)	7	
15	B65-H2151-10	.FUSE (15A)	2	
16	B65-H2151-60	.FUSE (30A)	2	
17	B65-H2151-80	.FUSE (2A)	3	
18	1LB-H2151-00	.FUSE (10A)	2	
19	1SD-H5700-00	.THERMISTOR ASSY	1	
20	4WA-81980-00	.DIODE ASSY	1	
21	3WP-81980-00	.DIODE ASSY	2	
22	95022-06012	BOLT, FLANGE	2	
23	90464-36800	CLAMP	1	
24	90464-24230	CLAMP	1	
25	90464-10008	CLAMP	1	
26	90464-12018	CLAMP	1	
27	90464-10112	CLAMP	1	(160X8.00)

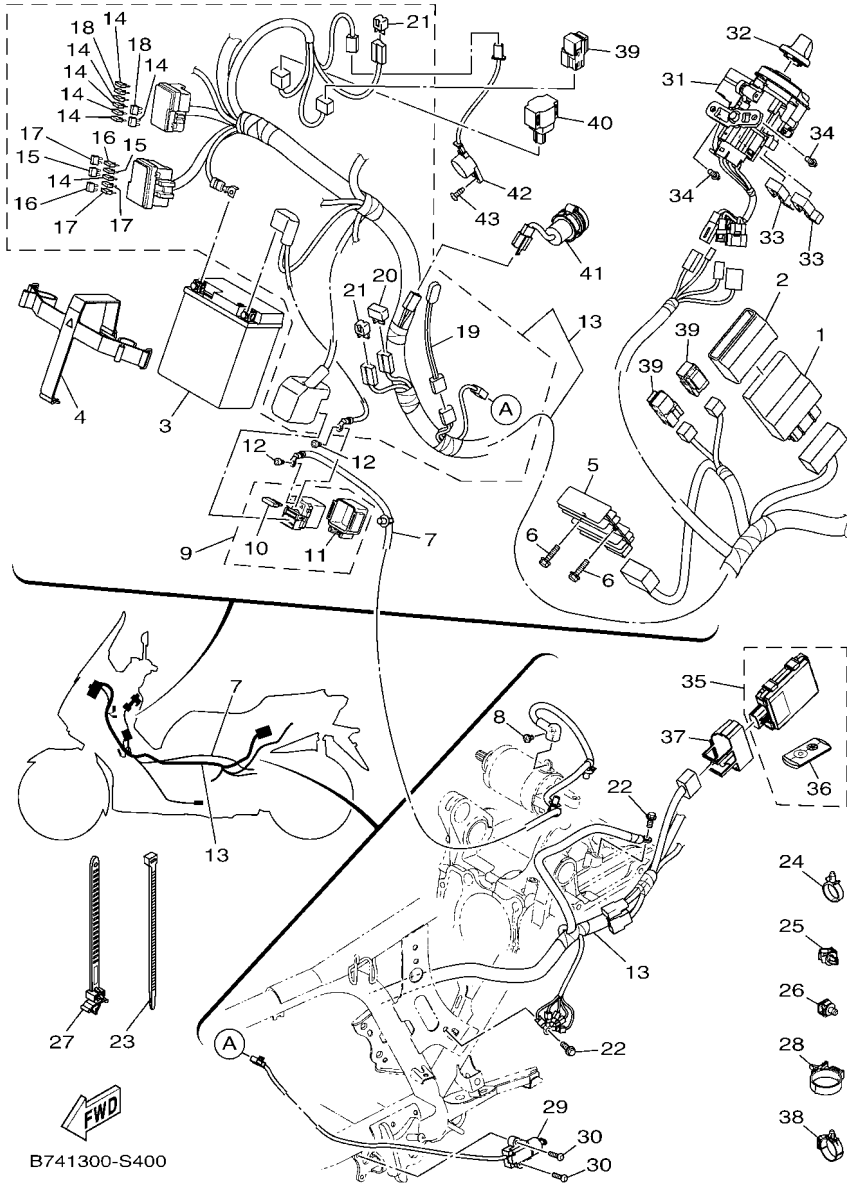
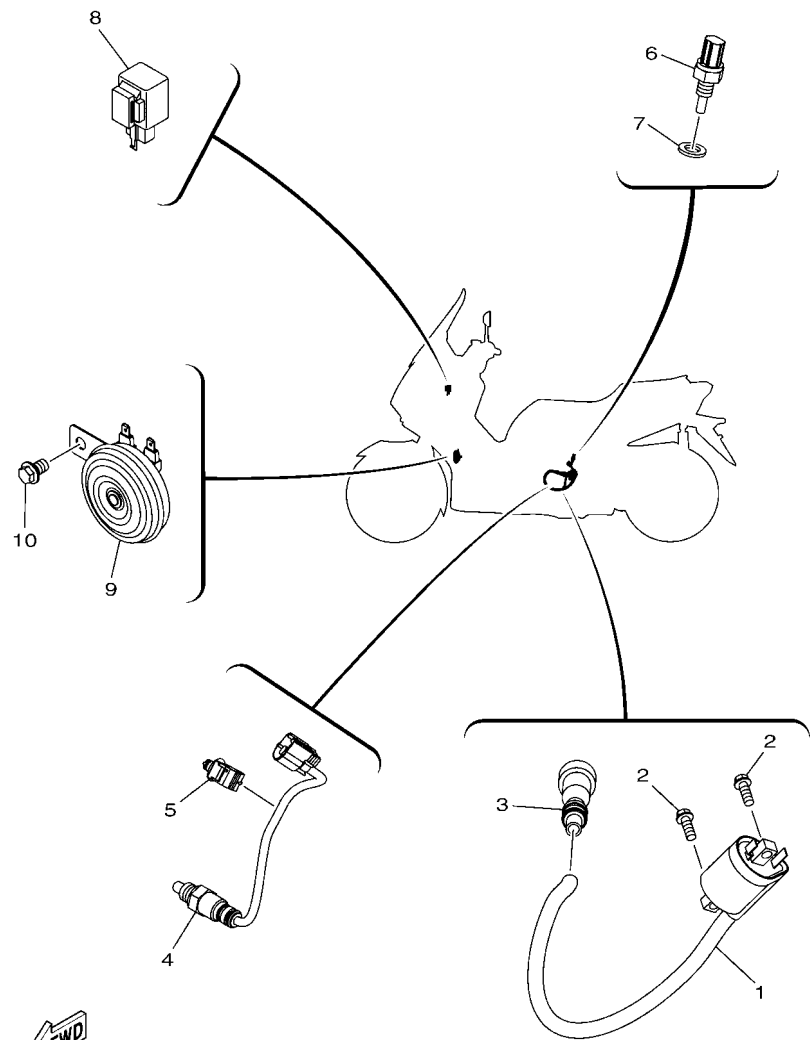

FIG. 40 ELECTRICAL 1

REF. NO.	PART NO.	DESCRIPTION	B74C				REMARKS
28	90464-36006	CLAMP	1				
29	B74-H2566-00	SWITCH, SIDE STAND	1				
30	90111-05810	BOLT,HEX. SOCKET BUTTON	2				
31	B74-H2501-00	MAIN SWITCH STEERING LOCK	1				
32	B74-H276E-00	KNOB COMP.	1				
33	90464-09806	CLAMP	2				
34	90109-06319	BOLT	2				
35	B74-H6260-40	REMOTE CONTROL UNIT ASSY	1				
36	B74-H6261-40	.XMTR. COMP.	1				
37	B65-H5546-00	BAND	1				
38	90464-30001	CLAMP	1				
39	B74-H1950-00	RELAY ASSY	3				
40	1PA-H2576-00	SENSOR, LEAN ANGLE	1				
41	BB8-H254B-00	TERMINAL COMP.	1				
42	B3F-H3383-00	BUZZER	1				
43	97702-50016	SCREW, TAPPING	1				

FIG. 41 ELECTRICAL 2



B741300-S410

REF. NO.	PART NO.	DESCRIPTION	B74C				REMARKS
1	B74-H2310-00	IGNITION COIL ASSY	1				
2	95022-06016	BOLT, FLANGE	2				
3	B74-H2370-00	PLUG CAP ASSY	1				
4	B74-H592A-10	SENSOR, OXYGEN	1				
5	90464-12018	CLAMP	1				
6	54P-H3591-00	THERMO UNIT	1				
7	90430-10804	GASKET	1				
8	4GY-83350-00	FLASHER RELAY ASSY	1				
9	1WD-H3371-00	HORN	1				
10	95022-08012	BOLT, FLANGE	1				

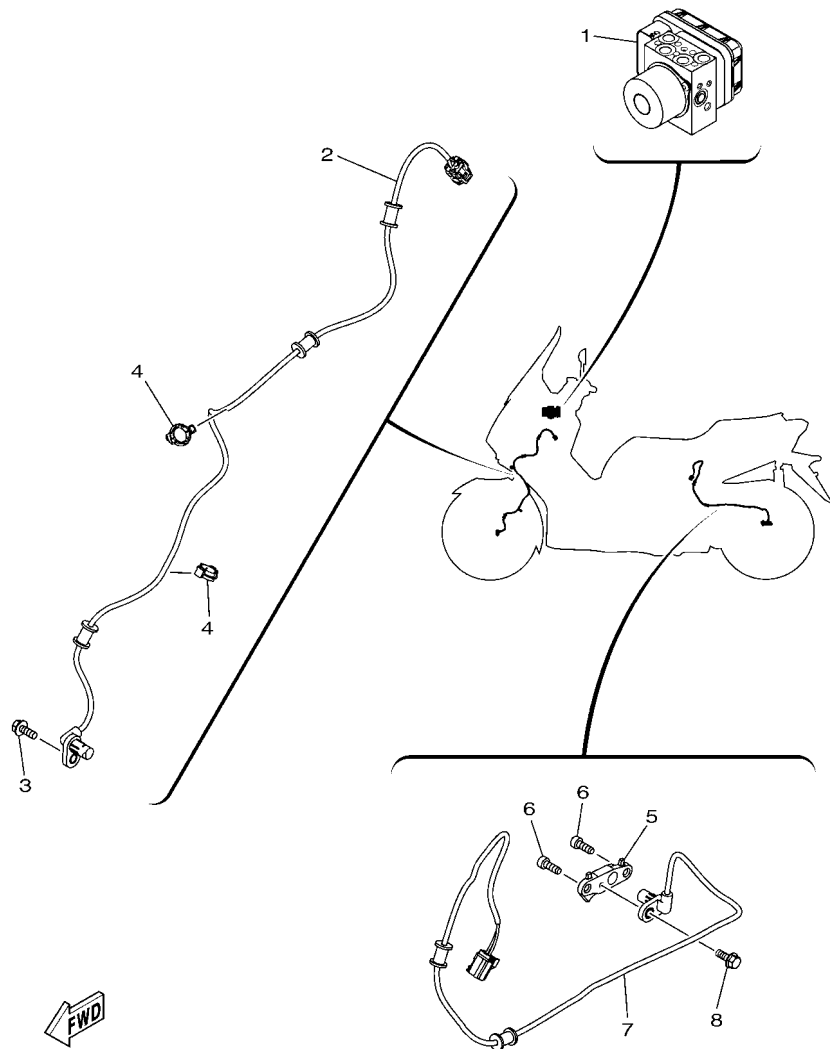

B741300-S420

FIG. 42 ELECTRICAL 3

REF. NO.	PART NO.	DESCRIPTION	B74C				REMARKS
1	B74-H5930-09	HYDRAULIC UNIT ASSY	1				
2	B74-H5970-00	WHEEL SENSOR ASSY, FRONT	1				
3	95802-06016	BOLT, FLANGE	1				
4	90464-14803	CLAMP	2				
5	B74-H5112-00	BRACKET, REFLECTOR 1	1				
6	91312-06016	BOLT, HEXAGON SOCKET HEAD	2				
7	B74-H5980-00	WHEEL SENSOR ASSY, REAR	1				
8	95802-06016	BOLT, FLANGE	1				

NUMERICAL INDEX

PART NO.	REF. NO.	PART NO.	REF. NO.	PART NO.	REF. NO.	PART NO.	REF. NO.	PART NO.	REF. NO.	PART NO.	REF. NO.
B74-11391-00	1 - 18	B74-1216A-00	3 - 13	34X-25937-00	26 - 7	B74-E2439-00	5 - 2	B74-E4711-00	9 - 2	B74-E7660-00	13 - 7
B74-11416-00	2 - 9	B74-1216A-20	3 - 13	3WP-81980-00	40 - 21	B74-E2446-00	6 - 39	54D-E4714-00	9 - 3	B74-E7664-00	13 - 11
B74-11416-10	2 - 9	B74-1216A-40	3 - 13	4WA-81980-00	40 - 20	B74-E2450-00	5 - 12	1WD-E4715-00	9 - 4	B74-E7668-00	13 - 20
B74-11416-20	2 - 9	B74-1216A-60	3 - 13	1YT-83311-00	38 - 3	B74-E2461-00	6 - 13	B74-E4718-00	9 - 6	B74-E7670-00	13 - 8
B74-11416-30	2 - 9	B74-1216A-80	3 - 13		38 - 9	B65-E2462-00	6 - 32	B74-E475P-00	9 - 10	B74-E7674-00	13 - 5
B74-11416-40	2 - 9	B74-1216A-A0	3 - 13	4GY-83350-00	41 - 8	B74-E2467-00	6 - 36	B74-E476P-00	9 - 11	B74-E7674-10	13 - 12
B74-11416-50	2 - 9	B74-1216A-F0	3 - 13	B74-E1102-00	1 - 1	B74-E2481-00	6 - 21	B74-E477P-00	9 - 12	B74-E7678-01	13 - 16
B74-11416-A0	2 - 9	B74-1216A-H0	3 - 13	B74-E111F-00	4 - 8	B74-E2482-00	6 - 26	B74-E4799-00	9 - 9	B74-E7678-10	13 - 18
B74-11417-00	2 - 10	B74-1216A-K0	3 - 13	40D-E1126-00	10 - 9	B74-E2483-00	6 - 27	2PV-E5113-00	10 - 19	B74-E7683-00	13 - 13
B74-11417-10	2 - 10	B74-1216A-M0	3 - 13	B74-E112F-00	4 - 6	B74-E2484-00	6 - 33	B74-E5150-00	10 - 1	B74-E7684-00	13 - 14
B74-11417-20	2 - 10	B74-1216A-R0	3 - 13	B74-E1133-10	1 - 2	B74-E2576-00	6 - 4	5D9-E5155-00	10 - 2	B74-F1110-11	15 - 1
B74-11417-30	2 - 10	B74-1216A-U0	3 - 13	B74-E1166-00	8 - 39	B74-E2591-00	6 - 30	5LW-E5363-00	10 - 24	B74-F1121-00	22 - 25
B74-11417-40	2 - 10	B74-1216A-W0	3 - 13	B74-E1169-00	1 - 11	5ST-E2615-00	6 - 8	5BP-E5363-10	5 - 6	B74-F1400-01	15 - 7
B74-11417-50	2 - 10	B74-1216A-Y0	3 - 13	B74-E1181-00	1 - 20	B74-E2662-00	3 - 11	B74-E5372-00	10 - 3	B74-F149S-00	15 - 5
B74-11417-A0	2 - 10	31G-12210-01	4 - 16	B74-E1185-00	1 - 10	1WD-E2671-00	6 - 11	B74-E5373-00	10 - 10	B74-F1511-00	16 - 1
B74-11650-00	2 - 2	31G-12214-00	4 - 18	B74-E1191-00	1 - 9	5ST-E2843-00	6 - 9	B74-E5378-00	10 - 4	B74-F1513-00-P4	16 - 4
2C0-11654-00	2 - 3	31G-12222-00	4 - 17	B74-E1193-00	1 - 13	B74-E3300-00	7 - 1	B74-E5407-00	11 - 9	B74-F1513-00-P5	16 - 4
B74-11656-00	2 - 5	B74-12410-00	6 - 1	4YS-E1198-00	10 - 21	4ST-E3411-00	7 - 4	B74-E5411-00	11 - 1	B74-F1514-00-P4	16 - 6
B74-11656-10	2 - 5	52S-12439-00	6 - 2	B74-E1311-00	1 - 24	1S7-E3440-00	7 - 7	B74-E5417-00	5 - 3	B74-F1514-00-P5	16 - 6
B74-11656-20	2 - 5	5GJ-12675-00	6 - 12	B74-E1351-00	1 - 25	B74-E3447-00	7 - 8	B74-E5421-00	10 - 26	BG6-F1578-00	16 - 10
B74-11656-30	2 - 5	5RU-13490-00	7 - 5	B74-E1400-00	2 - 1	B74-E3585-00	8 - 1	B74-E5431-00	11 - 5	BG6-F1578-10	16 - 10
B74-12168-00	3 - 13	52S-13938-00	8 - 9	B74-E1500-00	2 - 11	B74-E3595-00	8 - 2	B74-E5451-00	11 - 2	B74-F1611-00	16 - 22
B74-12168-20	3 - 13	B74-15338-00	11 - 14	B74-E1603-00	2 - 15	B74-E3750-01	8 - 13	B74-E5453-00	10 - 15	B74-F1621-00	22 - 15
B74-12168-40	3 - 13	5PW-15361-00	5 - 16	B74-E1631-01	2 - 14	B74-E3761-00	8 - 6	B74-E5461-00	10 - 27	B74-F1651-00	16 - 11
B74-12168-60	3 - 13	B74-17411-00	14 - 1	B74-E1633-00	2 - 16	B74-E3770-00	8 - 5	B74-E5471-00	11 - 7	1WD-F1668-01	22 - 42
B74-12168-80	3 - 13	4G0-21639-00	16 - 29	B74-E1998-00	1 - 7	B74-E3907-00	21 - 5	B74-E5474-00	11 - 10	B74-F1711-00-P0	30 - 23
B74-12168-A0	3 - 13		31 - 47	B74-E1999-00	1 - 14	3C1-E3915-00	21 - 8	2DP-E5481-00	11 - 6	B74-F1711-00-P2	30 - 23
B74-12168-F0	3 - 13	4HC-23125-20	20 - 5	B74-E2111-00	3 - 1	B74-E3971-00	21 - 13	B74-E5512-00	12 - 1	B74-F171E-00-P4	17 - 23
B74-12168-H0	3 - 13		20 - 23	B74-E2113-00	3 - 4	54P-E4137-00	8 - 10	5BP-E5521-00	12 - 2	B74-F171E-00-P5	17 - 23
B74-12168-K0	3 - 13	22W-23146-L0	20 - 6	B74-E2117-00	3 - 6	54P-E4147-00	8 - 7	B74-E5524-00	12 - 3	B74-F171L-00-P4	30 - 5
B74-12168-M0	3 - 13		20 - 24	5TL-E2118-00	3 - 5	5CA-E4147-00	8 - 8	B74-E5590-00	12 - 4	B74-F171L-00-P5	30 - 5
B74-12168-R0	3 - 13	2N4-23168-00	20 - 18	54P-E2119-00	3 - 3	54P-E416A-00	8 - 17	B74-E5744-00	13 - 17	B74-F171M-00-P4	30 - 16
B74-12168-U0	3 - 13		20 - 36	B74-E2121-00	3 - 2	54P-E4243-00	8 - 15	B74-E6111-00	14 - 12	B74-F171M-00-P5	30 - 16
B74-12168-W0	3 - 13	3FV-23462-00	20 - 40	2PH-E2126-00	3 - 7	B74-E4335-00	8 - 18	B74-E6151-00	14 - 2	B74-F1721-00-P0	30 - 27
B74-12168-Y0	3 - 13	3C1-24512-00	21 - 7	B74-E2146-00	3 - 10	B74-E4411-00	8 - 19	B74-E6611-00	13 - 21	B74-F1721-00-P2	30 - 27
B74-12169-10	3 - 13	B74-2476U-00	22 - 8	B74-E2151-00	3 - 8	B74-E4412-00	8 - 20	B74-E6620-00	13 - 19	B74-F172A-00	16 - 14
B74-12169-30	3 - 13	B74-2476V-00	22 - 9	B74-E2157-00	5 - 4	B74-E4417-00	8 - 33	B74-E7211-00	14 - 6	B74-F172F-00	16 - 18
B74-12169-50	3 - 13	5MT-25398-00	23 - 7	B74-E2161-00	3 - 9	B74-E4435-00	8 - 30	B74-E7412-00	13 - 27	2DP-F172W-00	30 - 11
B74-12169-70	3 - 13		25 - 4	B74-E2170-00	4 - 1	B74-E4437-00	8 - 22	B74-E7421-00	14 - 5	B74-F1731-00-P4	17 - 1
B74-12169-90	3 - 13	5MT-25398-10	23 - 7	B74-E2176-00	4 - 4	52B-E443E-00	8 - 27	B74-E7465-00	13 - 9	B74-F1731-00-P5	17 - 1
B74-12169-E0	3 - 13		25 - 4	B74-E2213-00	4 - 19	5TP-E443G-10	8 - 31	B74-E7465-10	13 - 10	2PH-F1737-00	32 - 64
B74-12169-G0	3 - 13	5MT-25398-20	23 - 7	1DB-E2228-00	4 - 15	B74-E4449-00	8 - 29	B74-E7611-00	13 - 6	B74-F173B-00	17 - 11
B74-12169-J0	3 - 13		25 - 4	B74-E2231-00	4 - 11	B74-E4452-00	8 - 24	B74-E7620-00	13 - 1		17 - 22
B74-12169-L0	3 - 13	5RB-25854-00	28 - 3	B74-E2233-00	4 - 12	B74-E4462-00	8 - 34	B74-E7623-00	13 - 3	B74-F1741-00-P4	17 - 12
B74-12169-N0	3 - 13		28 - 21	B74-E2241-00	4 - 14	B74-E4469-00	8 - 21	B74-E7632-00	13 - 2	B74-F1741-00-P5	17 - 12
B74-12169-T0	3 - 13	36Y-2589H-00	28 - 5	B74-E2405-00	6 - 10	B74-E447F-00	8 - 43	B74-E7641-00	13 - 23	B74-F1816-00	17 - 29
B74-12169-V0	3 - 13		28 - 23	B74-E240A-00	6 - 7	B74-E4611-00	9 - 1	B74-E7644-00	13 - 15	B74-F1817-00	17 - 30
B74-12169-X0	3 - 13	5KN-25926-01	26 - 17	B74-E2422-00	5 - 1	1WD-E4613-00	9 - 13	B74-E7653-00	13 - 4	B74-F1823-00	6 - 22

NUMERICAL INDEX

PART NO.	REF. NO.	PART NO.	REF. NO.	PART NO.	REF. NO.	PART NO.	REF. NO.	PART NO.	REF. NO.	PART NO.	REF. NO.
B74-F1871-00	17 - 25	B74-F3441-00	19 - 12	B74-F478E-00	22 - 27	5YP-F5925-01	24 - 9	B74-F8332-00	32 - 25	B74-H1950-00	40 - 39
1S7-F1875-01	17 - 26	B74-F3442-00	19 - 11	B74-F478G-00	22 - 23		26 - 11	B74-F8336-00	31 - 28	2GS-H1960-01	40 - 5
B74-F2100-00	18 - 1	B74-F3469-00	17 - 10	B74-F479D-00	22 - 38	5YP-F5937-00	24 - 7	B74-F8346-00-P0	31 - 4	1WD-H2100-00	40 - 3
B74-F2141-00	15 - 8		17 - 21	B74-F483H-00	21 - 23	1WD-F5939-51	26 - 13	B74-F8349-00	31 - 17	B74-H2129-00	32 - 55
B74-F2210-00	18 - 11	B74-F4110-01	21 - 1	B74-F5168-00-33	23 - 1	1WD-F5939-61	26 - 14	B74-F834F-00	31 - 14	B74-H212B-00	32 - 12
5MX-F2216-00	10 - 8	B74-F4135-00	21 - 20	2DP-F517G-00	23 - 8	B74-F6110-00	27 - 1		31 - 32	B74-H2131-00	40 - 4
	18 - 5	B74-F414A-00	21 - 17		25 - 5	B74-F6144-00	27 - 13		31 - 51	1LB-H2151-00	40 - 18
B74-F2591-00	6 - 24	B74-F414B-00	32 - 42	B74-F5181-00	23 - 11	B74-F6145-00-P0	27 - 21	B74-F8351-00-P4	32 - 34	B65-H2151-00	40 - 14
B74-F2865-00-P0	32 - 52		32 - 51	B74-F5183-00	18 - 8	4US-F6199-00	31 - 18	B74-F8351-00-P5	32 - 34	B65-H2151-10	40 - 15
B74-F286F-00	32 - 29	5D9-F414G-00	21 - 3	B74-F5338-00-33	25 - 1		31 - 34	B74-F8357-00	31 - 20	B65-H2151-60	40 - 16
B74-F3102-00	20 - 1	B74-F4170-00	21 - 22	1WD-F5802-00	24 - 4	B74-F6213-00	27 - 17	B74-F835J-00-P0	32 - 39	B65-H2151-80	40 - 17
B74-F3103-00	20 - 19	1DW-F4180-02	21 - 19	1WD-F5802-50	26 - 4	2DP-F6240-00	27 - 3	B74-F835J-00-P1	32 - 39	B74-H2151-A0	40 - 10
B74-F3110-00	20 - 3	B74-F419A-00	21 - 14	1WD-F5803-00	24 - 5	2DP-F6241-00	27 - 2	B74-F835K-00-P0	32 - 48	1WD-H2155-00	40 - 11
	20 - 21	B74-F4313-00	21 - 18	1WD-F5803-50	26 - 5	1PA-F6246-10	27 - 4	B74-F835K-00-P1	32 - 48	B74-H2310-00	41 - 1
5BP-F3111-10	20 - 17	B74-F4314-00	21 - 21	B74-F5805-00	24 - 12	B74-F6280-00	27 - 11	B74-F836P-00	32 - 23	B74-H2370-00	41 - 3
	20 - 35	B74-F4315-00	21 - 28	B74-F5806-00	26 - 15	B74-F6290-00	27 - 12	B74-F835X-00	31 - 38	B74-H2501-00	40 - 31
2JK-F3114-00	20 - 16	B74-F4316-00	21 - 31	B74-F5807-00	28 - 2	B74-F6301-00	27 - 6	B74-F8365-00	31 - 39	B74-H251P-00	15 - 3
	20 - 34	B74-F4425-00	21 - 11		28 - 20	B74-F637G-00	27 - 9	B74-F836B-00	27 - 23	2DP-H2530-00	28 - 29
B74-F3118-00	20 - 15	3C1-F4486-00	21 - 10	B74-F580U-00	24 - 3	B74-F7111-00	29 - 6	B74-F836K-00	31 - 1	BB8-H254B-00	40 - 41
	20 - 33	B74-F4494-00	31 - 56	B74-F580W-00	26 - 3	45P-F7114-00	29 - 8	B74-F836L-00	31 - 7	B74-H2566-00	40 - 29
B65-F3123-00	20 - 41	3C1-F4519-00	21 - 6	B74-F581J-00	28 - 42	4YY-F7114-00	29 - 16	B74-F836M-00	31 - 24	1PA-H2576-00	40 - 40
B74-F3126-00	20 - 2	B74-F452E-00	21 - 24	B74-F582U-00	24 - 1	B74-F7261-00	29 - 9	B74-F8377-00-P4	32 - 43	B74-H2590-01	40 - 13
B74-F312H-00	19 - 9	B74-F454E-00	21 - 25	B74-F582W-00	26 - 1	B74-F7311-00	29 - 11	B74-F8377-00-P5	32 - 43	B74-H2591-00	40 - 2
B74-F3136-00	20 - 20	B74-F4610-00	21 - 16	5TL-F5838-00	26 - 18	B74-F741L-00	29 - 19	B74-F837L-00	31 - 63	B74-H276E-00	40 - 32
B74-F3141-00	20 - 13	B74-F4639-00	22 - 22	1WD-F5852-00	28 - 4	B74-F742L-00	29 - 28	B74-F837M-00	31 - 65	B74-H3310-00	35 - 1
	20 - 31	B74-F465B-00	22 - 33		28 - 22	B74-F7430-00	29 - 17	B74-F837N-00	32 - 1	2CB-H3311-00	35 - 2
5BP-F3144-00	20 - 9	B74-F465E-00	22 - 32	3C1-F5855-00	28 - 7	2DP-F7431-01	29 - 18	B74-F837U-00	32 - 59		35 - 9
	20 - 27	B74-F470F-00	22 - 3		28 - 25	B74-F7437-00	29 - 24	B74-F8385-00	29 - 1	B74-H3312-00	35 - 3
5BP-F3145-00	20 - 7	B74-F471D-00	22 - 36	B74-F5867-00	28 - 6		29 - 33	B74-F838L-00	31 - 15	B74-H3320-00	35 - 8
	20 - 25	B74-F4723-00	22 - 10		28 - 24	B74-F7440-00	29 - 26	B74-F838N-00	29 - 4	B74-H3322-00	35 - 10
2JK-F3149-01	20 - 14	B74-F4727-00	22 - 20	B74-F5870-00	28 - 19	2DP-F7441-01	29 - 27	B74-F838V-00	31 - 33	1WD-H3371-00	41 - 9
	20 - 32	B74-F472T-00	22 - 30	B74-F5870-10	28 - 1	B74-F7481-00	30 - 1	B74-F838W-00	31 - 52	B3F-H3383-00	40 - 42
22W-F3156-L0	20 - 8	B74-F4730-00	22 - 1	B74-F5872-00	28 - 14	B74-F7483-00	30 - 31	B74-F839L-00	31 - 9	B74-H3500-00	36 - 1
	20 - 26	B74-F473R-00	22 - 6	B74-F5873-00	28 - 32	B74-F7484-00	30 - 32	B74-F839V-00	31 - 26	B74-H3511-00	36 - 3
2BU-F3158-00	20 - 11	B74-F4741-00	22 - 2	B74-F5874-00	28 - 35	B74-F7488-00	30 - 12	B74-F839W-00	31 - 46	B74-H353L-00	36 - 2
	20 - 29	B74-F474A-00-P4	17 - 4	B74-F5875-00	28 - 38	B74-F7493-00	30 - 33	B74-F842A-00	32 - 61	B74-H3572-00	36 - 4
2CM-F3166-00	20 - 10	B74-F474A-00-P5	17 - 4	B74-F5876-00	28 - 47	B74-F7494-00	30 - 34	B74-F842M-00	31 - 61	54P-H3591-00	41 - 6
	20 - 28	B74-F474E-00	22 - 24	B74-F587A-00	28 - 50	B74-F74A8-00-P0	31 - 44	B74-F843C-00	32 - 62	B74-H3912-00	28 - 26
B74-F3170-00	20 - 4	B74-F474W-00-P4	17 - 15	B74-F5886-00	28 - 17	B74-F8100-00	22 - 40	B74-H1410-00	33 - 2	B74-H3922-00	28 - 8
	20 - 22	B74-F474W-00-P5	17 - 15	B74-F5887-00	28 - 40	B74-F8175-00	22 - 41	B74-H1450-00	33 - 1	B74-H3963-00	39 - 1
31B-F3181-00	20 - 12	B74-F475M-00	22 - 7	1WD-F5914-50	26 - 16	B74-F818A-00	31 - 12	B74-H1801-00	34 - 2	B74-H3973-10	39 - 3
	20 - 30	1S7-F4768-00	22 - 39	5YP-F5917-00	24 - 8		31 - 30	B74-H1815-00	40 - 7	2DP-H3980-00	28 - 11
B74-F3317-00	24 - 14	B74-F4769-00	22 - 17		26 - 6		31 - 49	1WD-H1828-00	34 - 4	B74-H4140-00	35 - 5
B74-F3340-00	20 - 37	1DY-F4780-00	31 - 22	1WD-F5919-00	24 - 10	B74-F8306-00	32 - 22	4FP-H182L-00	34 - 5	B74-H4150-00	35 - 12
2JK-F3346-00	20 - 38		31 - 54	B74-F5919-50	26 - 9	B74-F8311-00	31 - 5	1WD-H1861-00	34 - 3	B74-H4300-00	37 - 1
5BP-F3416-10	19 - 2	B65-F4780-00	22 - 28	B74-F5921-50	26 - 12	B74-F8312-00-P0	31 - 59	B74-H1890-00	34 - 1	B74-H4547-00	38 - 19
5BP-F3418-00	19 - 5	B74-F4785-00	22 - 19	5YP-F5924-00	24 - 11	B74-F8321-00	32 - 6	B74-H1940-00	40 - 9	B74-H454J-00	38 - 20
B74-F3435-00	19 - 6	B74-F4786-00	22 - 4	1WD-F5924-50	26 - 10	B74-F8322-00	32 - 24	B74-H1948-00	34 - 6	B74-H4550-00	16 - 26

NUMERICAL INDEX

PART NO.	REF. NO.	PART NO.	REF. NO.	PART NO.	REF. NO.	PART NO.	REF. NO.	PART NO.	REF. NO.	PART NO.	REF. NO.
B74-H4710-00	38 - 1	90109-06887	32 - 13	90183-05807	16 - 12	90269-06816	22 - 16	90464-06008	28 - 45	90501-12743	29 - 29
B74-H4723-00	35 - 4		38 - 5		16 - 16		22 - 31	90464-07018	32 - 53	90506-32813	29 - 12
	35 - 11		38 - 11		16 - 20		27 - 20	90464-07805	28 - 46	90506-40805	29 - 7
1WD-H4726-00	38 - 21	90109-068A4	16 - 8		17 - 2		31 - 42	90464-09806	40 - 33	90508-13800	31 - 13
B74-H4730-00	38 - 7	90109-08232	24 - 2		17 - 13		31 - 60	90464-10008	21 - 30	90508-13801	31 - 31
B74-H4740-00	38 - 17	90110-06161	12 - 5		27 - 16		31 - 64		40 - 25	90508-14803	31 - 50
1WD-H4744-00	38 - 18		33 - 4		29 - 2		31 - 66	90464-10112	40 - 27	90520-04015	15 - 2
B74-H4748-00	38 - 23	90110-06172	8 - 4		30 - 6		32 - 4	90464-10802	6 - 6	90520-06808	31 - 10
B74-H4770-00	22 - 11		34 - 7		30 - 17		32 - 58	90464-12018	40 - 26		31 - 27
2FC-H5111-00	16 - 24	90110-06178	33 - 3		30 - 26	90269-07007	6 - 31		41 - 5	90520-10834	22 - 12
B74-H5112-00	42 - 5	90110-06182	4 - 13		30 - 30	90269-08007	32 - 63	90464-13185	21 - 2	90520-10835	11 - 13
3C1-H5130-00	38 - 15	90110-06187	4 - 7		31 - 6	90269-09005	30 - 7	90464-13801	31 - 35	90520-10836	8 - 42
B65-H5546-00	40 - 37	90110-06380	32 - 26		31 - 8		30 - 18	90464-14803	42 - 4	90520-10837	11 - 11
1SD-H5700-00	40 - 19	90110-06405	4 - 5		31 - 25	90280-05013	2 - 8	90464-16006	38 - 14	90520-20821	11 - 12
B74-H5752-00	21 - 9	90110-06868	1 - 23		31 - 45	90338-06809	22 - 13	90464-24230	40 - 24	91312-05008	40 - 12
B74-H5801-00	8 - 16	90111-05810	40 - 30		32 - 5	90338-14802	8 - 36	90464-30001	40 - 38	91312-05010	21 - 12
B74-H591A-00	40 - 1	90111-06807	9 - 7		32 - 16	90340-12808	10 - 20	90464-36006	40 - 28		22 - 37
B74-H592A-10	41 - 4	90111-06839	30 - 25		32 - 30	90340-18002	1 - 3	90464-36800	22 - 34	91312-05014	3 - 12
B74-H5930-09	42 - 1		30 - 29		32 - 41	90340-32805	5 - 10		40 - 23	91312-06016	42 - 6
B74-H5970-00	42 - 2		32 - 20		32 - 50	90387-06048	32 - 18	90467-09006	21 - 29	91312-06025	4 - 20
B74-H5980-00	42 - 7	90111-08087	26 - 2		32 - 54	90387-06158	32 - 37	90467-10038	6 - 5	91312-08030	19 - 8
B74-H6260-40	40 - 35	90119-06051	30 - 9		32 - 57		32 - 46	90467-12052	10 - 11	91317-06030	27 - 5
B74-H6261-40	40 - 36		30 - 20		37 - 5	90387-064W3	6 - 15	90467-12809	8 - 28	91402-25015	29 - 23
4C9-W0048-00	24 - 6		31 - 41		38 - 4	90387-06899	37 - 4		8 - 32		29 - 32
5YP-W0048-50	26 - 8		32 - 2		38 - 10	90387-068N8	32 - 9	90467-13808	8 - 40	91702-08038	29 - 22
B74-WE445-00	8 - 23	90119-068A2	21 - 4	90183-06818	27 - 15	90387-08839	17 - 9	90467-14807	8 - 41		29 - 31
90101-10830	29 - 13	90149-05029	23 - 9		31 - 16		17 - 20	90467-20805	6 - 28	91810-14809	10 - 16
90105-10883	2 - 6		25 - 6		31 - 53	90387-09805	32 - 14	90467-21801	6 - 29		10 - 28
90105-12805	15 - 10	90149-06104	27 - 22		32 - 17	90387-09808	32 - 19	90467-22002	6 - 19		11 - 3
90105-12806	15 - 9	90149-10804	24 - 13	90185-14801	23 - 13	90387-10849	29 - 15	90467-24800	6 - 20	92012-06010	27 - 7
90105-12807	13 - 25	90150-05024	32 - 60	90185-16800	18 - 10	90387-15834	23 - 10	90467-250A1	6 - 34	92012-06020	22 - 35
90109-06009	32 - 27	90160-05808	27 - 19	90201-06033	6 - 16	90387-15835	23 - 4	90467-26131	6 - 35	92017-05012	38 - 22
90109-06220	22 - 14		30 - 22	90201-06088	16 - 27	90387-17807	18 - 9	90468-18121	22 - 21	92017-05016	27 - 8
	31 - 58		30 - 24	90201-10118	28 - 16	90401-10812	28 - 15	90480-01558	32 - 33	93102-25826	14 - 14
90109-06319	40 - 34		30 - 28		28 - 34		28 - 33	90480-01559	17 - 3	93102-35805	10 - 14
90109-06577	28 - 10		31 - 2		28 - 37		28 - 36		17 - 14	93102-35806	14 - 11
	28 - 28		32 - 3		28 - 44		28 - 43		30 - 2	93103-10801	5 - 14
90109-06887	6 - 37	90167-05076	27 - 18	90201-10848	2 - 7	90430-06014	1 - 5		30 - 13	93106-22808	23 - 2
	16 - 17	90170-14802	13 - 26	90201-10849	1 - 17		5 - 9	90480-10289	32 - 7	93106-28801	18 - 3
	16 - 21	90179-05003	32 - 28	90201-15813	23 - 12	90430-08119	10 - 23		37 - 3	93106-28813	18 - 4
	16 - 23	90179-06055	16 - 3	90201-18262	10 - 5	90430-10148	5 - 5	90480-10332	9 - 8	93210-10096	7 - 6
	17 - 7	90179-06841	32 - 15	90201-19014	13 - 24	90430-10804	41 - 7	90480-13567	17 - 28	93210-12801	4 - 2
	17 - 18	90179-07001	2 - 4	90201-23015	13 - 22	90450-52008	8 - 38	90480-14023	32 - 36	93210-14816	10 - 25
	17 - 27	90179-10818	1 - 16	90202-26142	19 - 4	90450-56009	8 - 12		32 - 45	93210-18397	10 - 7
	29 - 3	90179-22025	19 - 7	90269-06812	31 - 40	90464-04004	30 - 3	90480-14229	32 - 8	93210-198J0	5 - 7
	30 - 8	90179-25810	19 - 3	90269-06816	6 - 38		30 - 14	90480-14818	6 - 18	93210-22800	6 - 40
	30 - 19	90183-05807	16 - 5		16 - 13		35 - 7	90480-15483	6 - 14	93210-32816	5 - 11
	31 - 37		16 - 7		21 - 27		35 - 14	90501-12743	29 - 20	93210-40659	8 - 3

NUMERICAL INDEX

PART NO.	REF. NO.	PART NO.	REF. NO.	PART NO.	REF. NO.	PART NO.	REF. NO.	PART NO.	REF. NO.	PART NO.	REF. NO.
93210-48530	7 - 10	95022-06025	11 - 4	95817-10040	18 - 12	97707-50012	31 - 36				
93300-205Y0	14 - 13	95022-06040	10 - 17	95817-10045	9 - 15	97707-50025	8 - 25				
93306-000Y3	5 - 13	95022-06060	7 - 2	95822-06025	40 - 6	97707-50035	8 - 26				
93306-002XH	4 - 3		10 - 18	95827-06020	6 - 41	98502-06012	8 - 14				
93306-078Y1	14 - 9	95022-06070	10 - 13	95827-06025	6 - 17	98507-05025	39 - 4				
93306-204XV	2 - 13	95022-08012	22 - 26	97527-05512	31 - 57	98507-05040	39 - 2				
93306-272YC	14 - 4		41 - 10	97602-04212	28 - 12	98902-05008	40 - 8				
93306-303YT	2 - 12	95022-08040	10 - 29		28 - 30	99009-10400	5 - 15				
	14 - 3	95022-08055	19 - 13	97702-30016	36 - 5	99009-18400	10 - 6				
93306-303YV	18 - 2	95027-06016	11 - 8	97702-40012	22 - 5	99009-28400	14 - 7				
93306-304YW	14 - 8	95027-06020	5 - 8	97702-40612	38 - 2	99009-40700	13 - 28				
93399-99932	20 - 39	95027-06025	28 - 13		38 - 8	99009-47500	18 - 6				
93399-999Y3	19 - 1		28 - 31	97702-50012	16 - 2	99009-52500	14 - 10				
933A6-202Y1	23 - 3	95027-06035	16 - 9		16 - 15	99530-08012	10 - 12				
93430-12809	29 - 10	95027-08035	9 - 5		16 - 19	99530-14016	1 - 21				
93450-17129	2 - 17	95602-06100	16 - 28		17 - 6		1 - 22				
93501-04830	29 - 21		28 - 9		17 - 17						
	29 - 30		28 - 27		30 - 4						
93900-00828	23 - 6	95602-10200	18 - 13		30 - 10						
	25 - 3		29 - 14		30 - 15						
94112-15800	23 - 5	95602-12200	15 - 11		30 - 21						
94114-14803	25 - 2	95612-08620	1 - 6		31 - 3						
94568-F9058	7 - 3	95702-05500	38 - 16		31 - 48						
94568-H8110	4 - 10	95702-06500	22 - 18		31 - 62						
94700-00436	1 - 19	95702-08500	9 - 14		32 - 32						
95022-06012	1 - 4	95707-05500	16 - 25		32 - 38						
	1 - 8	95802-06012	28 - 49		32 - 47						
	4 - 9		28 - 51		32 - 56						
	6 - 23	95802-06016	42 - 3		35 - 6						
	6 - 25		42 - 8		35 - 13						
	15 - 4	95802-06020	32 - 10		38 - 6						
	15 - 6		37 - 2		38 - 13						
	19 - 10	95802-06025	32 - 35	97702-50016	17 - 5						
	21 - 15		32 - 44		17 - 16						
	21 - 26	95807-06010	28 - 48		17 - 24						
	22 - 29	95807-06012	28 - 39		27 - 14						
	27 - 10		28 - 41		29 - 5						
	28 - 18	95812-06025	8 - 11		31 - 43						
	31 - 21	95812-06030	8 - 37		32 - 31						
	31 - 23	95812-08016	10 - 22		32 - 40						
	31 - 55		29 - 25		32 - 49						
	32 - 21		29 - 34		36 - 6						
	40 - 22	95812-08020	17 - 8		38 - 12						
95022-06016	1 - 12		17 - 19		40 - 43						
	41 - 2	95812-08055	32 - 11	97702-50020	8 - 35						
95022-06020	6 - 3	95812-10030	26 - 19	97707-50012	31 - 11						
	7 - 9	95812-10060	18 - 7		31 - 19						
95022-06025	1 - 15	95817-08030	18 - 14		31 - 29						